



Department of
Environmental
Conservation

2017 ANNUAL TECHNOLOGY REVIEW OF INNOVATIVE / ALTERNATIVE OWTS

Prepared for the

NEW YORK STATE DEPARTMENT OF ENVIRONMENTAL CONSERVATION

Innovative & Alternative Onsite Wastewater Treatment Systems
NYSDEC Grant Contract No.: DEC01-C00366GG-3350000 and DEC01-C00058GG-
3350000



Stony Brook
University

NYS Center for
Clean Water Technology

Version Dated: May 17, 2019 (FINAL SUBMISSION TO NYSDEC)
January 2, 2019 (DRAFT SUBMISSION TO NYSDEC)

Suffolk County Department of Health Services
360 Yaphank Avenue
Yaphank, NY, 11980

New York State Center for Clean Water Technology at Stony Brook University
Advanced Energy Research and Technology Center (AERTC)
1000 Innovation Road, Room 100
Stony Brook, NY 11794-6044

Reclaim  Our Water

No text this page



Preface

This Annual Technology Review for Innovative and Alternative Onsite Wastewater Treatment Systems is co-authored by the Suffolk County Department of Health Services (SCDHS) and the New York State Center for Clean Water Technology at Stony Brook University Center for Clean Water Technology (CCWT). The 2017 Annual Report was completed in 2018 based on data collected in 2017. Preparation of the next annual report will occur in 2019 and will include data acquired during 2018. However, it should be noted that as of December 21, 2018, fifty (50) Provisionally Approved I/A OWTS have been sampled with a cumulative average of 18.2 mg/L Total Nitrogen (165 total samples). Thus, at time of report issuance, the pool of provisionally approved technologies is meeting the current Suffolk County Sanitary Code goal of 19 mg/L total nitrogen for these systems.

CCWT has taken the liberty of including a report of our activities through December 2018, even though technically this report is prepared for 2017.



Executive Summary

This Annual Technology Review for Innovative and Alternative Onsite Wastewater Treatment Systems is co-authored by the Suffolk County Department of Health Services (SCDHS) and the New York State Center for Clean Water Technology at Stony Brook University (CCWT) (a.k.a. "Center"). This annual report is prepared pursuant to Attachment C – Work Plan in accordance with NYSDEC Grant No. DEC01-C00366GG-3350000. This report also serves as an annual review of I/A OWTS Technologies as required by Article 19 of the Suffolk County Sanitary Code.

The objective of the CCWT and Suffolk County Department of Health Services (SCDHS) programs is to develop, foster, and promote affordable, reliable, and effective Innovative and Alternative Onsite Wastewater Treatment Systems (I/A OWTS) that reduces the total nitrogen load to ground and surface waters originating from archaic cesspools and septic systems. An associated objective is the reduction of contaminant loads, such as pharmaceuticals and personal care products, via I/A OWTS technology.

This annual review is provided as a NYSDEC performance measure that presents the efforts made by both grant recipients (SCDHS and CCWT) to accomplish the goals set out in the grant. Herein we evaluate and compare current OWTS performance standards with best available technologies, which is to include technologies that have attained approval by Suffolk County. CCWT provides NYSDEC with an overview of the work conducted using Nitrogen Removing Biofilters (NRB). CCWT also introduces design and operational concepts of the Center's next generation of NRBs that are focused on improving nitrogen removal efficiencies while lowering overall cost of the system's installation.

Suffolk County initiated an I/A OWTS Demonstration Project in 2014 in which a total of 19 systems were donated from 4 manufacturers representing 6 different technologies. Following the success of the demonstration program SCDHS decided to launch a second phase of the I/A OWTS Demonstration Project in November of 2016. A total of seventeen (17) Phase 2 systems were installed as of December 31, 2017.

SCDHS performed monthly composite sampling on these systems and technologies that maintained an average of 19 mg/l or better over 75% of the systems for a minimum of 6 consecutive months were granted provisional approval, two (2) technologies received Provisional Approval in 2016 and an additional 2 technologies were approved in 2017. These results are summarized in the following table:

Technology	Average TN Concentration (mg/L)	Provisional Approval Status
Hydro-Action AN Series	11.6	Approved September 2016
Norweco Singular TNT	18.3	Approved October 2016
Orenco Advantex-RT	18.8	Approved March 2017
Norweco Hydro-Kinetic	17.4	Approved April 2017



Once systems are provisionally approved, manufacturers are required to sample the first twenty (20) year round systems every two (2) months for two (2) years. Norweco sampled four (4) systems bi-monthly in 2017 and the average was 32.3 mg/L TN. Norweco also sampled five (5) Hydrokinetic systems bi-monthly in 2017 and the average was 22.2 mg/L TN. Orenco sampled two (2) AX-RT systems bi-monthly in 2017 and the average was 31.9 mg/L TN. Hydro-Action sampled 6 systems bi-monthly in 2017 and the Average was 12.8 mg/L. Overall, Sixteen (16) Provisionally Approved I/A OWTS have been sampled with a cumulative average of 23 mg/L Total Nitrogen (63 total samples)

This figure provides a summary of all SCDHS sample results as of December 31, 2017.

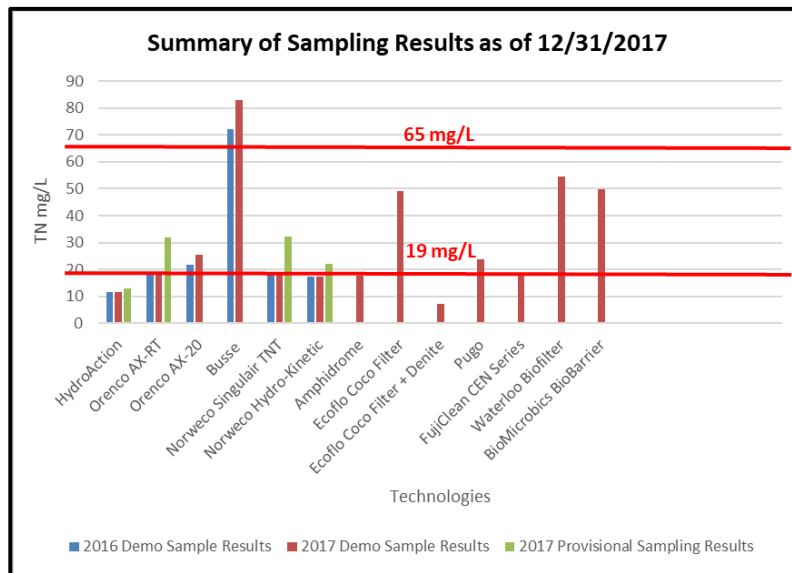

This figure provides a summary of the provisionally approved demonstration systems, by site, as of December 31, 2017.

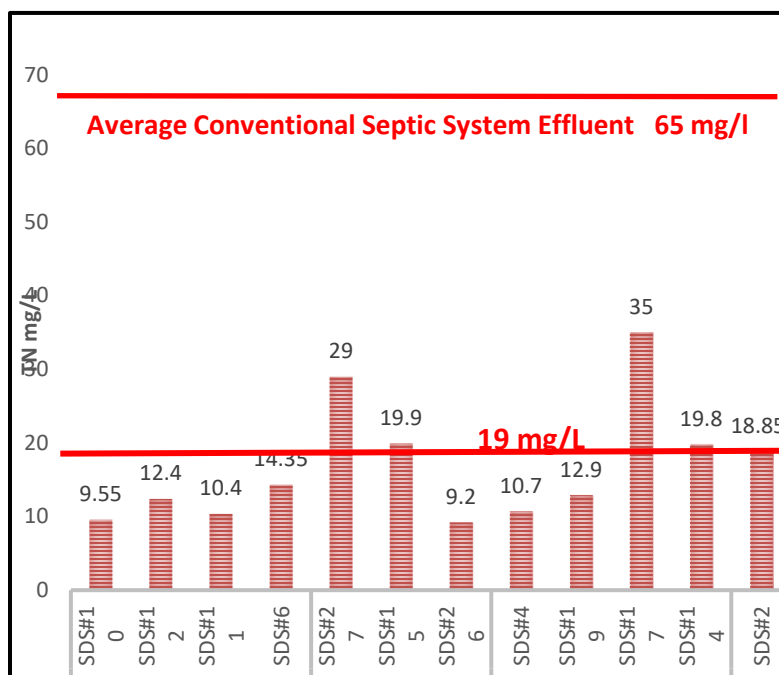



The following figure provides a summary of all demonstration systems as of December 31, 2017.

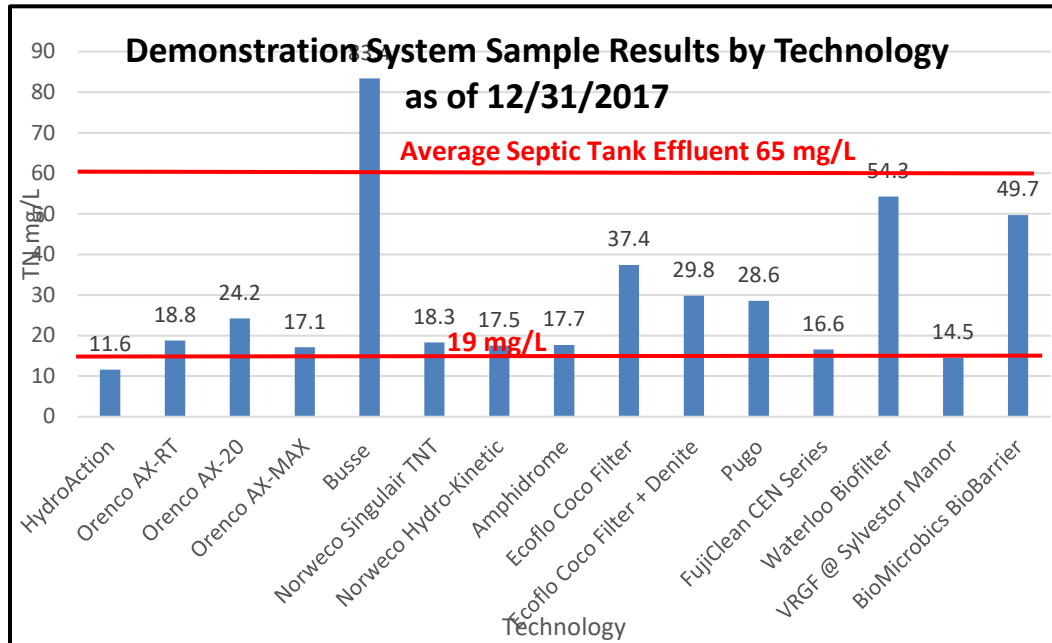

Two commercial systems were also sampled in 2017. An Orenco AX-MAX system is installed at Meschutt Beach in Hampton Bays and a vegetated recirculating gravel filter is installed at Sylvester Manor Educational Farm on Shelter Island. The AX-MAX system averaged 17.1 mg/L TN over 8 seasonal samples and the Vegetated Recirculating Gravel Filter averaged 15.2 mg/L TN over 3 seasonal samples. Increased sampling of commercial systems is planned for 2018.

CCWT has installed five (5) Nitrogen Removing Biofilters (NRBs) throughout Suffolk County in 2018 and has an additional three (3) systems in re-design since the received bids exceeded budget. System #6 should be constructed in early 2019. Upon installation of all nine (9) systems, CCWT will have installed three (3) NRBs, internally classified as “Lined”, “Unlined” and “Boxed”. CCWT has come to call these systems NRB 1.0. The following table summarizes the status of the NRBs installed in 2018:

NRB Ref.	Flow (GPD)	Project Location (Project Identifier)	System Type *	Septic Tank (Gals.)	Pump Station Size (Gals.)	Nitrification Sand Bed (S.F.)	Bed Loading Rate (GPD/S.F.)	Denitrification Box Size
1 ⁽¹⁾	550	9 Private Rd., Shirley, NY	Lined #1 (Saturated)	1,500	1,000	733	0.75	NA
2 ⁽¹⁾	440	59 River Rd., Shirley, N.Y.	Unlined #1 (Unsaturated)	1,000	1,000	880	0.50	NA
3 ⁽¹⁾	550	221 Old River Rd., Calverton, N.Y.	Box #1 (Saturated)	1,500	1,000	733	0.75	2,000
7 ⁽²⁾	440	Uplands Farms No. 1 (The Nature Conservancy)	Unlined #2 (Unsaturated)	1,000	1,000	587	0.75	NA
8 ⁽²⁾	440	Uplands Farms No. 2 (The Nature Conservancy)	Unlined #3 (Unsaturated)	1,000	1,000	587	0.75	NA

* CCWT Short Name Abbreviation for Type of System
 (1) NRB constructed and placed on-line in April / May 2018
 (2) NRB constructed and placed on-line in December 2018



These data plots show the results of CCWT's sampling program for the unlined and lined NRBs.

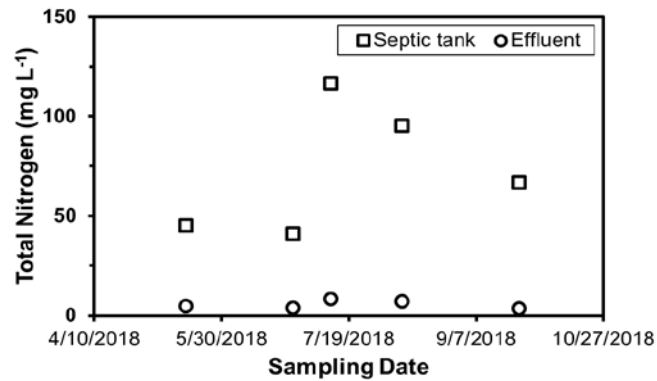
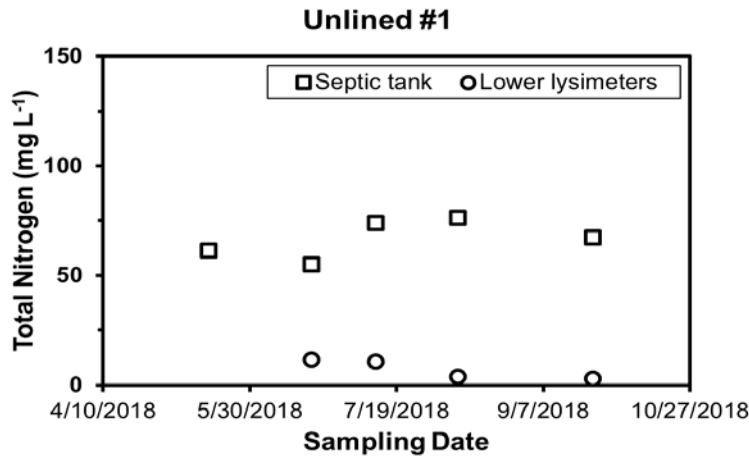

As shown, both systems are producing less than 10 mg/L of total nitrogen.

As of the writing of this technology review, 5 projects were constructed in 2018. The contract prices for the 5 installed systems are as follows:

- NRB System 1 (9 Private Drive): \$57,500
- NRB System 2 (59 River Road): \$65,800
- NRB System 3 (291 Old River Road): \$75,000
- NRB System 7 (TNC Upland Farms - Cottages #1 and #3): \$38,862



The following table summarizes the NRBs that are under redesign that are scheduled for installation in the first quarter of 2019.

NRB Ref.	Flow (GPD)	Project Location (Project Identifier)	System Type *	Status
4	220	67 Middle Island Road	Boxed #2	Under Re-Design
5	220	71 Yaphank Middle Island Road	Lined #2	Under Re-Design
6	550	264/300 Old River Road, Shirley, NY	Lined #3	P.O. Issued to Contractor
9	550	10 High Hold Drive Huntington, NY	Box #3	Under Re-Design

The Center has started development of the next generation of NRBs (a.k.a. NRB 2.0) with its principle purpose of reducing the cost for installation. The construction of CCWT's Research Facility is currently scheduled for full operation by the end of the first quarter of 2019. Research work continues on shallow drainfields, sources of carbon, wetlands treatment systems, and the use of membrane bioreactors for use in I/A Onsite Wastewater Treatment Systems (I/A OWTS).

Recommendations:

- The I/A OWTS Demonstration Program was an effective means by which to catalyze the use of innovative and alternative technologies in Suffolk County. The demonstration program allowed the assessment of system design, operation & maintenance, installation issues, and the overall ability of each technology to meet nitrogen reduction objectives in Suffolk County. Though all technologies participating in the demonstration program have certification for nitrogen reductions (through NSF245 or EPA's ETV testing), not all technologies proved capable of reducing total nitrogen to at or below 19 mg/L in Suffolk County.
- The performance standard of 19 mg/L represents the most stringent requirement for TN that does not allow for increase in density. The County should not consider changing the performance standard of 19 mg/L until there is sufficient data justifying a 90% confidence in the results as concluded by Horsely Witten Group in the analysis of Barnstable County's septic system database. (i.e. there should be a minimum of 12 samples of 20 systems of a technology before the County considers changing the performance standard from 19 mg/L TN).
- Although Provisionally Approved system were able to perform to the standard of 19 mg/L during demonstration testing, 3 out of 4 technologies are not currently meeting 19 mg/L during Provisional bi-monthly sampling. It is recommended that SCDHS meet with manufacturers in 2018 and address performance issues as it is still early in the Provisional Sampling phase and time to correct performance. SCDHS should request and require implementation of corrective action plans from Norweco and Orenco to improve their performance, and SCDHS should continue monitoring the performance of all provisionally approved systems to ensure compliance with standards are maintained.
- Field installed pilot NRB systems have been capable of reducing nitrogen to below 6 mg/L. Additional pilot testing is needed on year-round residences in Suffolk County.



- Further refinement of NRB's is required in order to bring the installation costs to affordable levels. CCWT has been working with the SCDHS to develop a cost efficient and passive I/A OWTS.



No text this page



TABLE OF CONTENTS

1.	PURPOSE OF ANNUAL TECHNOLOGY REVIEW	1-1
2.	SUFFOLK COUNTY RECLAIM OUR WATER INITIATIVE.....	2-1
2.1.	OVERVIEW	2-1
2.1.1.	LIQUID WASTE LICENSING	2-1
2.1.2.	LONG ISLAND NITROGEN ACTION PLAN (“LINAP”)	2-1
2.1.3.	SUFFOLK COUNTY SANITARY CODE AND STANDARDS FOR CONSTRUCTION	2-1
2.1.4.	SUFFOLK COUNTY SEPTIC DEMONSTRATION PROGRAMS	2-2
2.1.5.	SUBWATERSHEDS WASTEWATER PLAN (“SWP”)	2-2
2.2.	PERFORMANCE OF I/A OWTS IN SUFFOLK COUNTY	2-2
2.3.	SUFFOLK COUNTY’S SEPTIC DEMONSTRATION PROGRAMS:	2-5
2.3.1.	PHASE I - SEPTIC DEMONSTRATION SYSTEMS:	2-5
2.3.2.	SEPTIC DEMONSTRATION PROGRAM - LESSONS LEARNED:	2-6
2.4.	SUFFOLK COUNTY DEMONSTRATION SYSTEMS – PHASE I	2-6
2.4.1.	HYDRO-ACTION AN SERIES	2-7
2.4.2.	NORWECO SINGULAIR TNT	2-10
2.4.3.	ORENCO AX-RT SERIES	2-12
2.4.4.	NORWECO HYDROKINETIC	2-14
2.4.5.	ORENCO AX SERIES	2-16
2.4.6.	BUSS GT	2-17
2.4.7.	PHASE II - SEPTIC DEMONSTRATION SYSTEMS:	2-17
2.4.8.	AMPHIDROME	2-18
2.4.9.	ECOFLO COCO FILTER	2-19
2.4.10.	PUGO SYSTEM	2-20
2.4.11.	FUJICLEAN CEN SERIES	2-22
2.4.12.	WATERLOO BIOFILTER	2-23
2.4.13.	BIOMICROBICS BIOBARRIER	2-24
2.4.14.	BIOMICROBICS SEPTITECH STAAR	2-25
2.4.15.	BIOMICROBICS MICROFAST	2-25
2.5.	COMMERCIAL SYSTEMS	2-26
3.	CENTER FOR CLEAN WATER TECHNOLOGY	3-1
3.1.	OVERVIEW	3-1
3.2.	FIRST GENERATION NITROGEN REMOVING BIOFILTER (NRB 1.0)	3-2
3.2.1.	MASSTC PILOT INSTALLATIONS	3-2



3.2.2.	PRESSURIZED SHALLOW DRAINFIELDS _____	3-4
3.2.3.	FULL-SCALE EXPERIMENTAL INSTALLATIONS IN SUFFOLK COUNTY – INSTALLED SYSTEMS _____	3-5
3.2.4.	FULL-SCALE EXPERIMENTAL INSTALLATIONS IN SUFFOLK COUNTY – NOT YET INSTALLED _____	3-7
3.3.	NEXT GENERATION NITROGEN REMOVING BIOFILTERS (NRB 2.0) _____	3-8
3.3.1.	DESIGN CHARRETTE _____	3-8
3.3.2.	POST CHARRETTE BRAINSTORMING _____	3-10
3.3.3.	NRB 2.0 DESIGN _____	3-10
3.3.4.	PILOT TESTING OF NRB 2.0 _____	3-11
3.4.	CCWT WASTEWATER RESEARCH AND INNOVATION FACILITY (WRIF) (A.K.A. RESEARCH FACILITY) _____	3-11
4.	I/A OWTS TECHNOLOGIES IN USE IN PROXIMAL JURISDICTIONS	4-1
5.	I/A OWTS TECHNOLOGIES IN THE GLOBAL MARKET	5-1
6.	PUBLIC OUTREACH	6-1
6.1.	CCWT _____	6-1
6.2.	SUFFOLK COUNTY - INDUSTRY TRAINING & EDUCATION _____	6-2
6.3.	SUFFOLK COUNTY - PUBLIC OUTREACH _____	6-2
6.4.	2017 SUFFOLK COUNTY SEPTIC IMPROVEMENT PROGRAM SUMMARY _____	6-3
7.	EMERGING TECHNOLOGIES AND CCWT FUTURE RESEARCH NEEDS	7-1
7.1.	CONSTRUCTED WETLANDS _____	7-1
7.2.	BIOCHAR _____	7-3
7.3.	MBR USING CELLULOSE MEMBRANE & ANNAMOX _____	7-4
7.4.	MEMBRANE BIOREACTOR (MBR) USING CELLULOSE MEMBRANE _____	7-5
7.5.	PHARMACEUTICALS AND PERSONAL CARE PRODUCTS (PPCPs) _____	7-8
7.6.	POTENTIALLY TOXIC METALS (PTMs) _____	7-8
8.	EVALUATION OF O & M REQUIREMENTS OF EXISTING I/A OWTS.....	8-1
8.1.	NRB 1.0 O & M REQUIREMENTS _____	8-1
8.2.	O&M REQUIREMENTS FOR PROVISIONALLY APPROVED SYSTEMS _____	8-1
8.3.	O&M COSTS FOR PROVISIONALLY APPROVED SYSTEMS _____	8-1
8.4.	REPAIR AND REPLACEMENT COSTS FOR PROVISIONALLY APPROVED SYSTEMS _____	8-2
8.5.	ESTIMATED ELECTRICAL COSTS FOR PROVISIONALLY APPROVED TECHNOLOGIES _____	8-2
9.	CONCLUSIONS AND RECOMMENDATIONS.....	9-1



LIST OF FIGURES

Figure 1 – Phase I Suffolk County Demonstration Systems	2-7
Figure 2 - Phase II Demonstration I/A OWTS Technologies	2-18
Figure 3 - Performance Results for Unlined NRB	3-7
Figure 4 - Performance Results for Lined NRB	3-7
Figure 5 - Design Charrette Concepts	3-9
Figure 6 - NRB 2.0 Intermediate Bioreactor Process Schematic.....	3-10
Figure 7 - Research Facility with Expansion Area	3-12
Figure 8 - Nitrogen Speciation	7-1
Figure 9 - Marked Total Nitrogen Reductions	7-2
Figure 10 - Sylvester Manor Gravel Filter	7-2
Figure 11 - Nitrogen Adsorption Capacity	7-4
Figure 12 - MBBR-MBR	7-5
Figure 13 - Cross-Sectional SEM Images of the E-CNF1, E-CNF1, and E-CNF3 at Different Magnifications .	7-6
Figure 14 - Dynamic Contact Angle Measurements	7-7

LIST OF TABLES

Table 1 - Summary Approval Chart for Residential Systems	2-3
Table 2 - Approval for Commercial Systems	2-4
Table 3 - Sampling Requirements for Experimental and Piloting Use Approval	2-6
Table 4 – Hydro-Action AN Series Steady State 24-Hour Composite Sample Results.....	2-8
Table 5 – Hydro-Action AN Series Provisional Sample Results	2-9
Table 6 - Norweco Singulair TNT Steady State 24-Hour Composite Sample Results	2-10
Table 7 - Norweco Singulair TNT Provisional Sample Results.....	2-11
Table 8 - Orenco AX-RT Series Steady State 24-Hour Composite Sample Results.....	2-13
Table 9 - Orenco AX-RT Provisional Sample Results	2-13
Table 10 - Norweco Hydro-Kinetic Steady State 24-Hour Composite Sample Results.....	2-14
Table 11 - Norweco Hydro-Kinetic Provisional Sample Results	2-15
Table 12 - Orenco AX Series Steady State 24-Hour Composite Sample Results.....	2-16
Table 13 - Busse GT Steady State 24-Hour Composite Sample Results	2-17
Table 14 - Amphidrome Steady State 24-Hour Composite Sample Results	2-18
Table 15 - EcoFlo Coco Filter Steady State 24-Hour Composite Sample Results.....	2-19
Table 16 - EcoFlo Coco Filter with Additional Denitrification Filter Steady State	2-20



Table 17 - Pugo Steady State 24-Hour Composite Sample Results	2-21
Table 18 - FujiClean CEN Series Steady State 24-Hour Composite Sample Results	2-22
Table 19 - Waterloo Biofilter Steady State 24-Hour Composite Sample Results	2-24
Table 20 - BioBarrier Steady State 24-Hour Composite Sample Results	2-25
Table 21 - Orenco AX-MAX at Meschutt County Park.....	2-26
Table 22 - Vegetated Recirculating Gravel Filter at Sylvester Manor.....	2-26
Table 23 - Preliminary Data - Pressurized Shallow Drainfields	3-4
Table 24 - Installed NRB Systems	3-5
Table 25 - Summary of NRB Systems Not Yet Installed	3-8
Table 26 - I/A OWTS Approved in Proximate Jurisdictions	4-1
Table 27 - 2016 Comparison of I/A OWTS Results	4-2
Table 29 - Sylvester Manor Percent Removals of OWCs.....	7-8
Table 29 - MASSTC NRBs Percent Removals of OWCs	7-8
Table 30 - ICP-MS Data MASSTC (New York Systems).....	7-9
Table 31 - ICP-MS Data MASSTC (New York Systems) - 03/20/18 (ppb)	7-9

LIST OF APPEDICES

Appendix A: CCWT Research Facility Schematic Layout of Experiments



1. PURPOSE OF ANNUAL TECHNOLOGY REVIEW

This annual report is co-authored by the Suffolk County Department of Health Services (SCDHS) and the New York State Center for Clean Water Technology at Stony Brook University (CCWT) (a.k.a. "Center"). This annual report is prepared pursuant to Attachment C – Work Plan in accordance with NYSDEC Grant No. DEC01-C00366GG-3350000.

The objective of the CCWT and Suffolk County Department of Health Services (SCDHS) programs are to develop affordable, reliable, and effective Innovative and Alternative Onsite Wastewater Treatment System (I/A OWTS) that reduces the total nitrogen load to ground and surface waters originating from archaic cesspools and septic systems. Consistent with this objective is to reduce other contaminant loads, such as pharmaceuticals and personnel care products, via I/A OWTS technology.

This annual review is provided as a NYSDEC performance measure that presents the efforts made by both grant recipients (SCDHS and CCWT) to accomplish the goals set out in the grant. Herein we evaluate and compares current OWTS performance standards with best available technologies, which is to include technologies that have gained approval by Suffolk County. CCWT provides NYSDEC with an overview of the work conducted using Nitrogen Removing Biofilters (NRB). CCWT introduces design and operational concepts of the Center's next generation of NRBs that are focused on improving nitrogen removal efficiencies while lowering overall cost of the system's installation.

CCWT has adopted 3 core objectives regarding the development of an I/A OWTS, which we have termed "10-10-30", namely:

1. The system must produce a total nitrogen concentration of at least **10 mg/L**.
2. The homeowner cost to construct a typical system is approximately **\$10,000**.
3. The life cycle of the system is at least **30 years**.

In order to fully realize these objectives, CCWT has constructed the CCWT Wastewater Research and Innovation Facility (WRIF). The WRIF allows the Center to design and implement experiments that will yield technical design standards and the ultimate publication of a Guidance Document. The Guidance Document is required pursuant to Article 19 and provides relevant criteria and specifications to engineers and installers to use in the preparation of CCWT's I/A OWTS. Herein, we discuss the work that will be conducted at the WRIF.

This report also addresses I/A OWTS work and research conducted by the proximate jurisdictions of Massachusetts, Rhode Island, Maryland, and New Jersey and discuss the eventual expansion into global markets. We provide the reasoning for the use of statistical data trends in evaluating performance requirements of Article 19.

Finally, we introduce a preliminary plan to introduce the I/A OWTS technologies to the local, regional, national, and global marketplaces.



No text this page



2. SUFFOLK COUNTY RECLAIM OUR WATER INITIATIVE

The section reports the work being conducted by Suffolk County.

2.1. Overview

Water is the single most significant resource for which Suffolk County bears responsibility. In 2014 Suffolk County Executive Steve Bellone kicked off his Reclaim Our Water initiative by identifying water quality as his administration's highest priority. Since then, the County has participated in a four (4) State tour of Innovative and Alternative Onsite Wastewater Treatment Systems (I/A OWTS), adopted 2015's Comprehensive Water Resources Management Plan, initiated the Subwatersheds Wastewater Plan, piloted twelve (12) I/A OWTS technologies on forty (40) residential properties, adopted Article 19 of the sanitary code, and also amended the Residential Construction Standards for the first time since 1973. These efforts would not have been possible without the assistance of many stakeholders, most notably, New York State Department of Environmental Conservation (NYSDEC) and the Long Island Action Plan (LINAP). The Septic / Cesspool Upgrade Program Enterprise (SCUPE) is a DEC grant that enables Suffolk County to embark on these aggressive measures to battle nitrogen pollution.

Thousands of parcels are currently served by cesspools and septic systems with little to no nitrogen removing capabilities and may never be connected to a sewer system. Reversing degradation of water quality will depend on replacement of existing systems with new, individual Innovative and Alternative Onsite Wastewater Treatment Systems (I/A OWTS).

The following are key program components of the Reclaim Our Water initiative:

2.1.1. Liquid Waste Licensing

Suffolk County began septic industry licensing with eleven specialized endorsements under the "liquid waste umbrella" and required training, certification and continuing education for I/A OWTS installers. The installer must hold a current Liquid Waste License pursuant to Chapter 563 Article VII (Septic Industry Businesses) with an Endorsement as an Innovative and Alternative Treatment System Installer through the Suffolk County Department of Labor, Licensing and Consumer Affairs. The Department of Labor, Licensing, and Consumer Affairs maintains a list of liquid waste license holders Six (6) training classes were offered in 2017 with two hundred and five (205) total participants.

2.1.2. Long Island Nitrogen Action Plan ("LINAP")

The New York State Department of Environmental Conservation ("NYSDEC") partnered with Suffolk County to complete the LINAP and help improve wastewater treatment within Suffolk County to protect water resources. The NYSDEC has provided grant funding for the Suffolk County Septic/Cesspool Upgrade Program Enterprise ("SCUPE") for the evaluation of I/A OWTS, development of an I/A OWTS program, and to initiate the Subwatersheds Wastewater Plan to prioritize areas in need of improved wastewater treatment. The SCUPE funding enabled the County to hire start-up staff for the I/A OWTS Program and a Responsible Management Entity. It also provided funding for the Septic Improvement Program. Overall, these programs are early actions in the NYSDEC Long Island Nitrogen Action Plan, a multiyear initiative to reduce nitrogen in Long Island's surface and ground waters, in which Suffolk County participates as a partner.

2.1.3. Suffolk County Sanitary Code and Standards for Construction

Suffolk County Department of Health Services has prepared and implemented Article 19 Standards to regulate I/A OWTS and has since been updating the Standards and Sanitary Code in order to keep the County's regulations up to date with the progress of the I/A OWTS program and technology advances. The Standards also include how the Department serves as the Responsible Management Entity to administer and conduct a comprehensive set of activities and have the legal authority and technical capacity to ensure the long-term operation, maintenance, and management of all I/A OWTS in Suffolk



County. In 2017, the residential standards were revised to allow for the following: best-fit retrofits, procedures for conducting percolation tests, updated to gravelless absorption trenches and the addition of Pressurized Shallow Drainfields (PSD's) following I/A OWTS. In addition, the commercial standards were revised to allow for the following: I/A OWTS, best-fit retrofits, procedures for conducting percolation tests, and added gravelless absorption trenches/beds.

2.1.4. Suffolk County Septic Demonstration Programs

Demonstration Projects give I/A OWTS Manufacturers the opportunity to showcase and demonstrate single family residential onsite wastewater treatment system technologies in Suffolk County—at no cost to the County and participating homeowners — in an effort to test the viability of these systems in local conditions and potentially expedite provisional approval of said technologies. There have been two demonstration programs in Suffolk County, one beginning in 2014 and the other in 2016.

As of December 31, 2017, there have been 20 demonstration technologies installed in Suffolk County. Technologies participating in the demonstration program were offered a streamlined path to Provisional Approval. If 75% of the systems of a technology in the demonstration program maintained a dataset of 19 mg/L or better for a minimum of 6 months, they were granted Provisional Use Approval.

2.1.5. Subwatersheds Wastewater Plan (“SWP”)

The SWP is the science-based bridge that will serve to support policy decisions and provide a recommended blueprint for wastewater upgrades. The SWP is based on a series of models, data evaluations and cost-benefit analyses. The SWP will set priority areas, nitrogen reduction goals, and describes where, when, and what methods should be implemented to meet nitrogen reduction goals.

2.2. Performance of I/A OWTS in Suffolk County

All I/A OWTS technologies must be approved by the Department for use in Suffolk County as either an “Experimental”, “Piloting”, “Provisional”, or “General Use” system in order to be permitted for installation as an onsite wastewater treatment system in accordance with the Article 19 Standards. During each phase of approval, the I/A OWTS technology must undergo sampling as stated in the Article 19 Standards.

The minimum sampling requirements and resulting combined TN average outlined in Tables 1 and 2, and defined in the Article 19 Standard, shall be required prior to a system receiving approval to move from one phase of approval to the next and eventually to the final approval phase known as “General Use.” Tables 1 and 2 also summarize the approval process for both residential and commercial systems.



Table 1 - Summary Approval Chart for Residential Systems

Approval Phase	No. of Systems	Sampling Frequency	Performance Requirement
Experimental	3 – 5 Year-Round	Monthly Sampling 12 months rolling average	The total dataset of 75% of the systems must have a combined average of 19 mg/L or less TN
Piloting*	8 – 12 Year-Round	Monthly Sampling 12 months rolling average	The total dataset of 75% of the systems must have a combined average of 19 mg/L or less TN
Septic Demonstration Systems*	1 – 5 Year-round	Monthly Composite Samples 6 month rolling average for streamlined approval.	The dataset of 75% of the systems must maintain a combined average of 19 mg/L or less TN
Provisional 1	First 20 Year-Round	Bi-Monthly Sampling fo 24 months rolling average	The dataset of all the 20 systems must have a combined average of 19 mg/L or less TN
Provisional 2	All Other installations during Provisional Use Approval	Every 12 months, unless seasonal then every month of operation.	The annual dataset must maintain a combined average of 19 mg/L or less TN in order to remain in the Provisional phase ***
General Use		Every 36 Months	The dataset must maintain an average of 19 mg/L or less in order to remain in General Use phase **

Note: The number of required systems is a cumulative number. For example, the minimum of 20 systems for Provisional Use includes the number of systems installed as part of Experimental and Piloting phases.

**Suffolk County Sponsored I/A OWTS Demonstration Program may permit a streamlined Pilot approval phase.*

***The combined average of the dataset in Experimental, Piloting and Provisional 1 is the requirement to achieve successful completion of that phase.*



Table 2 - Approval for Commercial Systems

Approval Phase	No. of Systems	Sampling Frequency	Performance Requirement
Experimental*	3 – 5 year-round	Monthly Sampling 12 months rolling average	The total dataset of 75% of the systems must have a combined average of 19 mg/L or less TN
Piloting*	8 – 12 year-round	Monthly Sampling 12 months rolling average	The total dataset of 75% of the systems must have a combined average of 19 mg/L or less TN
Provisional 1	First 20 Systems Installed and systems installed in commercial subcategories**	Monthly Sampling for 12 months; bi-monthly sampling for an additional 12 months	The dataset of all the 20 systems must have a combined average of 19 mg/L or less TN
Provisional 2	All Other installations during Provisional Use Approval	Every 12 months, unless seasonal then every month of operation.	The annual dataset must maintain a combined average of 19 mg/L or less TN in order to remain in the Provisional phase ***
General Use	All Systems	Every 12 Months	The dataset must maintain an average of 19 mg/L or less in order to remain in General Use phase ***

Note: The number of required systems is a cumulative number. The minimum of 20 systems for Provisional Use includes the number of systems installed as part of Experimental and Piloting processes.

** Piloting and Experimental phases are identical for residential and commercial systems. A technology can advance to Provisional Approval after successfully completing piloting phase with residential systems, commercial systems, or any combination thereof.*

*** In order for a commercial technology to receive General Use Approval specific to any of the following subcategories: (1) office, retail, industrial, gym and dry goods; (2) restaurants, coffee shops, and other kitchen / fats, oils, and grease (FOG) waste; (3) multi-tenant residential; (4) institutional use; (5) medical use, a minimum of four (4) systems must be installed and successfully implemented in that specific subcategory.*

****The combined average of the dataset in Experimental, Piloting and Provisional 1 is the requirement to achieve successful completion of that phase. The combined average of the dataset in Provisional 2 and General Use shall be evaluated to affirm compliance to maintain approval or disclose non-performance to be considered for revocation*



2.3. Suffolk County's Septic Demonstration Programs:

In 2014, Suffolk County developed provisions for participation in an I/A OWTS Demonstration Program, whereby a Vendor installs, tests and maintains systems at no cost or at a reduced cost to Property Owner(s). This program is based on a similar program in Rhode Island where 58 I/A OWTS were installed, evaluated over a 10-year period to provide a means for industry training, performance evaluations, and provide data for the development of I/A OWTS regulations. Systems being tested as part of a Demonstration Program were subject to a streamlined approval process where the Department has approved a technology for Provisional Use if 75% of the units installed have a combined total average effluent TN of 19 mg/L or less for at least 6 months of composite sampling.

The Demonstration Program proved to be an exceptional tool to assess the design, operation, maintenance, installation, and overall ability of an I/A OWTS technology to meet nitrogen reduction objectives in Suffolk County. The dual-purpose framework of the program also included a means for accelerated construction of programmatic infrastructure and validation of its and local institutional ability to review, approve, install and operate I/A OWTS systems. As part of this approach Suffolk County dedicated significant staff resources to work with manufacturers, who also committed to terms of an intensive cooperative program, including:

- Industry training (designers, installers, O&M contractors)
- Regulatory training (procedures/standards to review/approve, and inspect)
- Cooperative process optimization; i.e., vendors working with Suffolk to optimize systems (recirculation rates, oxygen supply, etc.) given local influent strength, venting configurations, etc.
- Demonstration of systems to design professionals, non-governmental organizations (NGOs), civics, local governments, etc.

A technology's successful completion of a demonstration program allows admittance into the Provisional phase, where rigorous testing and statistical protocols are utilized prior to granting general use approval. The dual-purpose framework of the program included:

2.3.1. Phase I - Septic Demonstration Systems:

In April of 2014, Suffolk County issued the first Request for Expression of Interest (RFEI) for a Demonstration Program of Innovative and Alternative Onsite Wastewater Systems (I/A OWTS). A total of 19 systems were donated from 4 manufacturers representing 6 different technologies. Following the County-wide lottery for the interested homeowners, the systems were installed between June 24, 2015 and February 29, 2016 and 2 technologies received Provisional Approval in 2016 and another 2 technologies received approval in 2017.

The systems were given three (3) months to reach equilibrium and were then sampled monthly. Systems were granted Provisional Use Approval if the dataset from 75% of the systems averaged 19 mg/l or less for a minimum of 6 consecutive months.

Table 3 provides a summary of the sampling requirements for each parameter of interest.



Table 3 - Sampling Requirements for Experimental and Piloting Use Approval

Parameter	Sample Type	Testing Location
BOD ₅	24 h composite	Laboratory
Total suspended solids	24 h composite	Laboratory
pH	Grab	Test site
Temperature (wastewater)	Grab	Test site
Temperature (ambient air)	Grab	Test site
Effluent Alkalinity (as CaCO ₃)	24 h composite	Laboratory
TKN (as N)	24 h composite	Laboratory
Ammonia-N (as N)	24 h composite	Laboratory
Nitrite-N (as N)	24 h composite	Laboratory
Nitrate-N (as N)	24 h composite	Laboratory

2.3.2. Septic Demonstration Program - Lessons Learned:

- Aesthetics and yard disruption are the most important factors to homeowners when selecting a system. Technologies with more than 3 lids and a footprint larger than a conventional septic tank will not be as widely used as I/A systems that take up a smaller footprint.
- Homeowners who take an active role in their septic system project, especially those that make a financial investment are more likely to be satisfied with the project and operate the I/A OWTS in accordance with manufacturer recommendations.
- Although all technologies in the Septic Demonstration Program had NSF 245, or ETV Certification, not all technologies are capable of meeting performance standards under actual residential conditions in Suffolk County.
- Not all preexisting sites are able to meet Department Standards and setbacks. The Department should develop best-fit standards for upgrades and retrofits of existing systems with I/A OWTS

2.4. Suffolk County Demonstration Systems – Phase I

Figure 1 depicts the systems included in Phase I of the program.



Figure 1 – Phase I Suffolk County Demonstration Systems

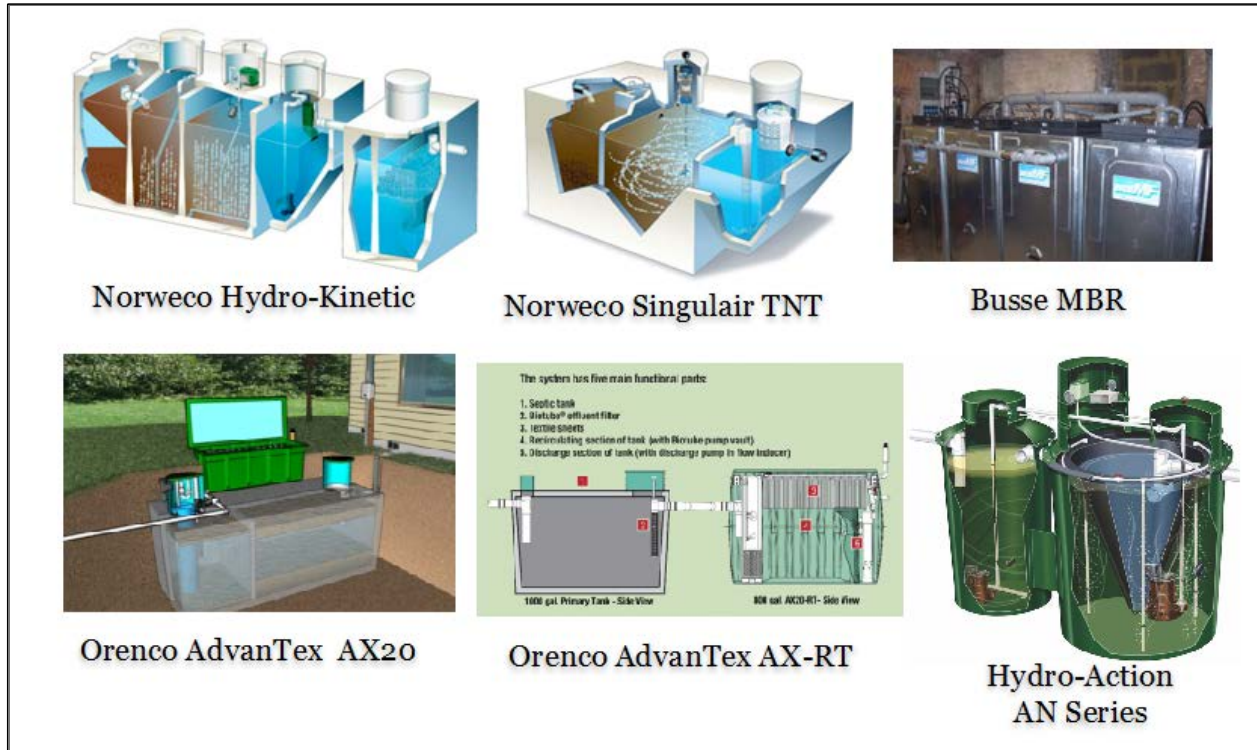

2.4.1. Hydro-Action AN Series

The Hydro-Action systems utilize a suspended growth aeration system. The treatment occurs as wastewater enters the pretreatment tank and flows by gravity into the aeration compartment. Wastewater flows by gravity from the aeration chamber through a hole in the base of the cone shaped clarifier, where final settling takes place. The hydraulic roll created by the aeration system helps draw settled solids out of the base of the clarifier and back into the aeration chamber. The aerobically-charged wastewater is then recirculated back to the pretreatment tank, where it further denitrifies. Treated wastewater exits by gravity through a tee structure located in the center of the clarifier, treated effluent is then discharged to a Department approved leaching structure.

Five (5) Hydro-Action AN systems were installed as part of the Septic Demonstration Program. The systems were sampled from May 2016 through November 2016 and averaged 11.9 mg/L TN. The dataset of 75% of the systems maintained an average of 11.6 mg/L TN. Hydro-Action was granted Provisional Use Approval on September 28, 2016. 20 year-round Provisional Use systems are required to be sampled by the manufacturer every 2-months for a 24-month period. Hydro-Action sampled 6 systems bi-monthly in 2017. The average of all systems was 12.8 mg/L TN.



Table 4 – Hydro-Action AN Series Steady State 24-Hour Composite Sample Results

Site #	Sample Date	Calculate	TN (mg/l)	TKN (mg/l)	Ammonia (as N)	NO3 (Nitrate as N)	NO2 (Nitrite as N)	BOD	TSS	PH	Temp	Alk
SDS#18	5/16/16-5/17/16	No	18.7	2.4	<0.5	15.8	0.5	16	16	6.56	60.3	18
	6/20/16 - 6/21/16	No	24.8	8.5	0.8	16.3	<0.5	N/R	67	6.77	70.8	26.8
	7/18/16 - 7/19/16	No	10.6	5.3	<0.5	5.3	<0.5	18	53	7.07	80	65
	8/15/16 - 8/16/16	No	4.5	<0.5	<0.5	4.5	<0.5	>9	<10	7.17	80	68
	9/12/16 - 9/13/16	No	9	2.3	<1.0	6.7	<0.5	N/R	<10	7.13	73	54.4
	11/14/16-11/15/16	No	10.1	7.9	3.8	2.2	<0.5	18	33	6.57	56	23.3
SDS#10	5/9/16 - 5/10/16	Yes	5.7	<0.5	<0.5	3.6	2.1	19	16	6.6	59.3	22
	6/13/16-6/14/16	Yes	9.7	2	<0.5	7.7	<0.5	<17	<10	7.34	N/R	N/R
	7/11/16-7/12/16	Yes	14.1	2.2	<0.5	11.9	<0.5	9	10	6.94	77	318
	8/8/16 - 8/9/16	Yes	8.8	<1.0	1.4	8.8	<0.5	<17	14	7.08	78	45.6
	9/12/16 - 9/13/16	Yes	9.7	2.9	<1.0	6.8	<0.5	N/R	10	7.33	73	48
	10/17/16 - 10/18/16	Yes	9.3	2	<0.5	7.3	<0.5	11	10	7.32	N/R	58
SDS#12	5/9/16 - 5/10/16	Yes	14.1	5.1	<0.5	9	<0.5	27	<25	7.09	58.5	52
	6/13/2016-6/14/16	Yes	12.2	2	<0.5	10.2	<0.5	<16	<10	7.75	72.4	111
	7/11/16-7/12/16	Yes	14.5	4.9	<0.5	9.6	<0.5	22	53	7.63	69	138
	8/8/16 - 8/9/16	Yes	10.4	6.1	3.5	4.3	<0.5	55	90	6.88	74	176
	9/12/16 - 9/13/16	Yes	12.1	1.8	<1.0	10.3	<0.5	N/R	10	7.64	72	110.2
	10/17/16 -10/18/16	Yes	11.1	1.7	<0.5	9.4	<0.5	<7	<10	7.52	N/R	76
SDS#11	5/9/16 - 5/10/16	Yes	5.2	<0.5	<0.5	2.4	2.8	37	<25	7.08	59.2	72
	6/13/16 - 6/14/16	Yes	10.8	2.3	<0.5	8.5	<0.5	<17	<10	7.16	71.6	35
	7/11/16 to 7/12/16	Yes	10.5	2.6	<0.5	7.9	<0.5	11	11	6.83	72.4	27
	8/8/16 - 8/9/16	Yes	10.1	<1.0	<0.5	10.1	<0.5	10	<10	6.69	73	23
	9/12/16 - 9/13/16	Yes	13.4	3.2	<1.0	10.2	<0.5	N/R	22	6.02	80	10
	10/17/16-10/18/16	Yes	12.6	3.3	<0.5	9.3	<0.5	14	23	6.67	71	20
SDS#6	5/16/16-5/17/16	Yes	11.3	5.5	3.6	5.2	0.6	<16	13	7.49	58.6	54.5



6/20/16 - 6/21/16	Yes	24.2	4.9	<0.5	19.3	<0.5	N/R	<10	7.22	70.4	23.5
7/18/16 - 7/19/16	Yes	12.8	0.9	<0.5	11.9	<0.5	<9	<10	7.42	80	54
8/15/16-8/16/16	Yes	13.9	9.3	1.2	2.2	2.4	10	<10	7.75	75	163
9/12/16 - 9/13/16	Yes	4.3	1.8	<1.0	2.5	<0.5	N/R	<10	7.72	72	88.6
11/14/16-11/15/16	Yes	19.6	3.8	<0.5	15.2	0.6	7	<10	7.19	50	53.2
Average		11.9	3.8	2.4	8.5	1.5	19	28	7.12	69.9	70.4

Note: The TN average for Hydro-Action during the Pilot Demonstration was 11.6 mg/l calculated using all TN results labeled as “Yes” under the “Calculate” Column.

Table 5 – Hydro-Action AN Series Provisional Sample Results

SITE	Sample Date	TN (mg/l)	TKN (mg/l)	Ammonia (as N)	NO3 (Nitrate as N)	NO2 (Nitrite as N)	BOD	TSS	PH	Temp	Alk
PS #1/	8/2/2017	9.3	2.2	< 0.5	7.1	< 0.5	N/A	N/A	7.1	N/A	N/A
SDS# 18	11/8/2017	8.7	0.9	N/A	7.8	< 0.5	N/A	N/A	N/A	N/A	N/A
	12/13/2017	15.7	< 0.1	< 0.1	15.7	< 0.05	< 4	10	6.8	15	7.4
PS #2/	8/2/2017	11.5	1.4	< 0.5	10.1	< 0.5	N/A	N/A	6.7	N/A	N/A
SDS# 10	11/16/2017	31.7	8	N/A	23.7	< 0.5	N/A	N/A	N/A	N/A	N/A
	12/14/2017	11.4	1.4	0.12	10	< 0.05	< 4	13	6.9	15	26.8
PS#3/	8/2/2017	13.1	6.2	0.65	6.9	< 0.5	N/A	N/A	7.4	N/A	N/A
SDS#12	11/2/2017	17.7	4.2	N/A	13.5	< 0.5	N/A	N/A	N/A	N/A	N/A
	12/14/2017	12.4	2.8	0.16	9.3	0.34	< 4	48	7.2	16	36.2
PS#4/	8/2/2017	14.1	3.7	0.51	10.4	< 0.5	N/A	N/A	6.3	N/A	N/A
SDS# 11	11/16/2017	13.2	2.6	N/A	10.6	< 0.5	N/A	N/A	N/A	N/A	N/A
	12/14/2017	12.9	4.5	1.7	8.4	< 0.05	< 4	< 10	6.9	16	13.4
PS# 5/	8/2/2017	4.1	0.9	< 0.5	3.2	< 0.5	N/A	N/A	7.5	N/A	N/A
SDS# 6	11/8/2017	4.7	1.5	N/A	3.2	< 0.5	N/A	N/A	N/A	N/A	N/A
	12/13/2017	7.8	< 0.1	< 0.1	7.8	< 0.05	5.4	11	7.1	15	40.8
Average		12.8	3.1	0.61	9.8	0.38	4	24	7	15	25.5



2.4.2. Norweco Singulair TNT

The Singulair wastewater treatment system is a self-contained three-chambered treatment system utilizing primary treatment (settling), mechanical aeration, clarification, and flow equalization to achieve treatment. Wastewater from the building enters the primary settling chamber through an inlet tee, then enters an aeration chamber. In the aeration chamber, an aspirator at the bottom of a shaft disperses air radially as fine bubbles provide oxygen for the biomass and vertically mix chamber contents. The wastewater in the aeration chamber passes through to the clarification chamber for final settling of solids. Treated wastewater passes through an effluent filter as it exits the system and is then gravity fed to the leaching structure.

Five (5) Singulair TNT systems were installed as part of the Septic Demonstration Program. The systems were sampled from May 2016 through November 2016 and averaged 20.9 mg/L TN. The dataset of 75% of the systems maintained an average of 18.3 mg/L TN. Norweco Singulair TNT was granted Provisional Use Approval on October 7, 2016.

It is noted that no samples were taken from the fifth Norweco Singulair TNT site due the fact the homeowner would not grant SCDHS employees' access to the site. The average was based on the 4 sites that were sampled.

20 year-round Provisional Use systems are required to be sampled by the manufacturer every 2-months for a 24-month period. Norweco sampled 4 systems bi-monthly in 2017. The average of all systems was 32.3 mg/L TN.

Table 6 - Norweco Singulair TNT Steady State 24-Hour Composite Sample Results

Site #	Sample Date	Calculate (Yes or No)	TN (mg/l)	TKN (mg/l)	Ammonia (as N)	NO3 (Nitrate as N)	NO2 (Nitrite as N)	BOD	TSS	PH	Temp	Alk
SDS#21	9/19/16 - 9/20/16	No	23	12.4	6.2	1.1	9.5	79	62	6.96	74	82
	10/3/16-10/4/16	No	42.6	36.6	35.7	5.4	0.6	197	108	N/R	74	N/R
	11/21/16-11/22/16	No	57.4	52.2	40.1	<0.5	5.2	197	88	7.43	64	262
SDS#27	5/9/16 - 5/10/16	Yes	15.3	15.3	<0.5	<0.5	<0.5	86	110	6.82	59	131
	6/13/16 - 6/14/16	Yes	26.1	23.5	1.1	2.6	<0.5	96	232	7.15	73.6	142.5
	7/11/16-7/12/16	Yes	31.1	22.5	3.9	8.6	<0.5	111	190	6.87	70	150
	8/8/16 - 8/9/16	Yes	10.7	<0.1	<0.5	10.7	<0.5	19	16	7.64	N/R	123
	9/19/16 - 9/20/16	Yes	46.2	30.2	8.1	16	<0.5	171	384	6.85	76	116
	10/3/16-10/4/16	Yes	44.6	20.2	2	24.4	<0.5	124	232	6.34	64	N/R
SDS#15	3/21/16 - 3/22/16	Yes	14	14	2.3	<0.5	<0.5	48	90	6.81	62	102
	4/18/16-4/19/16	Yes	14.8	14	14.2	0.8	<0.5	<16	27	7.12	57.6	146
	5/16/16-5/17/16	Yes	22.2	5.6	2.3	16.6	<0.5	21	32	6.57	66.8	38.75
	6/20/16 - 6/21/16	Yes	15.8	5.2	1.5	10.6	<0.5	N/R	61	6.87	77.7	62



	7/18/16 - 7/19/16	Yes	17.3	12	<0.5	5.3	<0.5	78	82	6.88	81	110
	8/15/16 - 8/16/16	Yes	53.1	<0.5	<0.5	44.6	<0.5	55	160	6.49	84	51.2
	9/19/16 - 9/20/16	Yes	10.1	6.8	3.2	2.4	0.9	48	32	6.8	81	71
	10/3/16-10/4/16	Yes	6.3	3.3	<0.5	2.3	0.7	33	25	6.71	74	N/R
	11/21/2016-11/22/16	Yes	17.2	15.1	9.1	<0.5	2.1	64	34	6.84	65	93
SDS#26	3/14/16 - 3/15/16	Yes	15.4	15.4	5.4	<0.5	<0.5	73	87	6.77	47.6	N/R
	4/18/16-4/19/16	Yes	12.5	12.5	7.1	<0.5	<0.5	55	53	6.72	57.6	122
	5/9/16 - 5/10/16	Yes	12.8	12.8	5.3	<0.5	<0.5	53	81	6.66	58	77
	6/13/16 - 6/14/16	Yes	14.1	14.1	9.8	<0.5	<0.5	18	20	7.15	75.3	116
	7/11/16-7/12/16	Yes	13.7	13.7	10.6	<0.5	<0.5	25	37	6.94	77	112
	8/8/16 - 8/9/16	Yes	11.8	11.1	12.7	<0.5	0.7	13	19	7.04	74	122
	9/19/16 - 9/20/16	Yes	2.9	2.9	1.5	<0.5	<0.5	21	17	6.06	76	74
	10/3/16-10/4/16	Yes	3.7	2.3	2	1.4	<0.5	11	10	N/R	68	N/R
	11/28/16-11/29/16	Yes	9.1	5.2	0.6	3.9	<0.5	25	60	6.57	N/R	49
* SDS#16												
	Average		20.9	15.2	8.8	9.8	2.8	68	87	6.84	69.5	107

* This site removed from demo program due to homeowner issue. SCDHS was not allowed on site for sampling

Note: The TN average for Norweco Singlair TNT during the Pilot Demonstration was 18.3 mg/l calculated using all TN results labeled as "Yes" under the "Calculate" Column.

Table 7 - Norweco Singlair TNT Provisional Sample Results

SITE	Sample Date	TN (mg/l)	TKN (mg/l)	Ammonia (as N)	NO3 (Nitrate as N)	NO2 (Nitrite as N)	BOD	TSS	PH	Temp	Alk
PS# 1/	8/2/2017	38.89	28.1	22.52	3.1	7.69	N/A	N/A	6.6	N/A	N/A
SDS# 21	10/30/2017	59.6	59.6	45.9	< 0.05	< 0.05	44	63	6.82	20.5	250
	11/16/2017	70	70	N/A	< 1	< 0.5	N/A	N/A	N/A	N/A	N/A
PS# 2/	8/2/2017	Pending	Pending	Pending	Pending	Pending	N/A	N/A	Pending	N/A	N/A
SDS# 27	8/10/2017	53.9	9.4	N/A	44.5	< 0.5	N/A	N/A	N/A	N/A	N/A



	10/30/2017	39.8	10.1	0.648	29.5	0.21	17	###	5.99	20.2	29
	11/2/2017	48.4	12.4	N/A	36	< 0.5	N/A	N/A	N/A	N/A	N/A
PS#3/	8/2/2017	12.2	12.2	5.68	< 1	< 0.5	N/A	N/A	6.5	N/A	N/A
SDS# 15	10/30/2017	11.9	5.46	0.645	6.19	0.22	5	33	6.37	21.3	56
	11/22/2017	21	13.1	N/A	5	2.9	N/A	N/A	N/A	N/A	N/A
PS# 4/	8/2/2017	23.3	20.7	2	2.6	< 0.5	N/A	N/A	6.4	N/A	N/A
SDS#26	10/30/2017	3.25	2.54	0.98	0.438	0.27	< 3	< 4	6.94	18	46
	11/22/2017	5.19	2.3	N/A	2.3	0.59	N/A	N/A	N/A	N/A	N/A
	Average	32.3	20.5	11.19	11.0	1.20	17	56	6.51	20	95

2.4.3. Orenco AX-RT Series

The AdvanTex® AX-RT Series is a recirculating textile filter treatment system. It is contained within a single fiberglass tank installed with the access panel at grade. It is preceded by a two-compartment septic tank and discharges to a leach field. Raw sewage enters the septic tank through its inlet tee. In the septic tank, the raw sewage separates into three distinct zones -- a scum layer, a sludge layer, and a clear layer. Effluent from the clear layer passes through a Biotube® effluent filter and is discharged by gravity to the recirculation treatment tank portion of the AX-RT unit, which contains a Biotube Pump Package.

The recirculation pump is timer controlled to ensure that small, intermittent doses (micro-doses) of effluent are applied to the textile sheets throughout the day. This ensures an aerobic, unsaturated environment for optimal treatment to occur. Effluent is sprayed over the textile sheets. The effluent then percolates down through the textile sheets and is distributed between the recirculation and discharge chambers by means of the AX-RT baffle. Periodically, a pump in the discharge chamber doses effluent to the dispersal system.

One (1) Orenco AX-RT system was installed as part of the Septic Demonstration Program. The system was sampled from February 2016 through September 2016. The dataset of 75% of the systems maintained an average of 18.95 mg/L TN

The 18.95 mg/l average above excluded two months of data for the Orenco RT system as the homeowner reported that a significant amount of bleach was discharged to the systems after cleaning coral from a fish tank. The Department made a decision to exclude the April and May 2016 samples and Provisional Use Approval was issued in April 2017. 20 year-round Provisional Use systems are required to be sampled by the manufacturer every 2-months for a 24 month period. Orenco sampled 2 systems bi-monthly in 2017. The average of all systems was 31.9 mg/L TN.



Table 8 - Orenco AX-RT Series Steady State 24-Hour Composite Sample Results

Site #	Sample Date	Calculate (Yes or No)	TN (mg/l)	TKN (mg/l)	Ammonia (as N)	NO3 (Nitrate as N)	NO2 (Nitrite as N)	BOD	TSS	PH	Temp	Alk
SDS#2	3/21/16 - 3/22/16	Yes	21.2	3.6	1.8	17.6	<0.5	<13	<10	6.24	54.3	64
	*4/11/16-4/12/16	No	70.9	68.1	42.2	0.5	2.3	12	N/R	6.14	N/R	47
	*5/16/16-5/17/16	No	35	3.8	3.2	31.2	0.5	<10	<10	6.16	67	45
	6/20/16 - 6/21/16	Yes	24.5	7.9	7.1	16.6	<0.5	N/R	<10	N/R	69.9	N/R
	7/18/16 - 7/19/16	Yes	19.7	12	0.5	7.7	0.8	<9	<10	6.55	78	135
	8/22/16 - 8/23/16	Yes	13.6	3.2	2.8	9.9	0.5	<9	<10	6.21	77	118
	9/26/16 - 9/27/16	Yes	19.6	19.6	16.1	<0.5	<0.5	24	13	9.87	77	228
	10/3/16-10/4/16	Yes	14.5	14.5	19.7	<0.5	<0.5	25	13	N/R	64	N/R
	Average		18.9	16.6	11.7	13.9	1.0	20	13	6.86	70	106

* Samples excluded based on homeowner report of significant bleach discharged to system for fish tank coral cleaning

Note: The TN average for Orenco AX-RT during the Pilot Demonstration was 18.5 mg/l calculated using all TN results labeled as "Yes" under the "Calculate" Column.

Table 9 - Orenco AX-RT Provisional Sample Results

SITE	Sample Date	TN (mg/l)	TKN (mg/l)	Ammonia (as N)	NO3 (Nitrate as N)	NO2 (Nitrite as N)	BOD	TSS	PH	Temp	Alk
PS# 1/	8/2/2017	23.3	1.3	1.84	22	< 0.5	N/A	N/A	6.6	N/A	N/A
SDS# 2	11/2/2017	31	1.2	1.21	29.8	< 0.5	N/A	N/A	N/A	N/A	N/A
	11/29/2017	32.1	3.9	2.5	28.2	< 0.5	< 4	< 5	6.81	24.3	30
PS#2/	8/2/2017	43.39	11.9	9.9	30.4	1.09	N/A	N/A	6	N/A	N/A
SDS# 43	11/8/2017	29.8	6.2	N/A	23.6	< 0.5	N/A	N/A	N/A	N/A	N/A
	11/22/2017	32	6.3	7.1	25.8	0.5	7.4	< 5	6.28	23.2	7.5
	Average	31.9	5.1	4.5	26.6	0.59	5.7	5	6.42	23.8	18



2.4.4. Norweco HydroKinetic

The HydroKinetic system uses extended aeration, attached growth, nitrification and denitrification processes to treat wastewater. It consists of four treatment chambers (pretreatment, anoxic, aeration and clarification) followed by a Hydro-Kinetic FEU filter containing filter media facilitating additional reduction of BOD and TSS by attached growth, prior to discharge to a leaching structure. The clarification chamber incorporates a flow equalization unit. Aeration is controlled by a factory-programmed timer and wastewater is recirculated from the clarifier back to the anoxic chamber at factory set intervals. The system is available with both concrete and HDPE tankage and with the pre-treatment tank either integral to the other three chambers in a four-chambered tank, or as a distinct tank.

Five (5) Norweco HydroKinetic systems were installed as part of the Septic Demonstration Program. The Department began sampling the systems in August 2016. The Hydrokinetic system averaged 24.6 mg/l in 2017 and the dataset of 75% of the systems maintained an average of 17.56 mg/L and was issued Provisional Use Approval in April of 2017. 20 year-round Provisional Use systems are required to be sampled by the manufacturer every 2-months for a 24 month period. Norweco sampled 5 systems bi-monthly in 2017. The average of all systems was 22.2 mg/L TN.

Table 10 - Norweco Hydro-Kinetic Steady State 24-Hour Composite Sample Results

Site #	Sample Date	Calculate (Yes or No)	TN (mg/l)	TKN (mg/l)	Ammonia (as N)	NO3 (Nitrate as N)	NO2 (Nitrite as N)	BOD	TSS	PH	Temp	Alk
SDS#4	8/22/16 - 8/23/16	Yes	4.2	<1.0	0.5	4.2	<0.5	<9	25	7.53	81	136
	9/26/16 - 9/27/16	Yes	8.7	1.4	<0.5	7.3	<0.5	9	12	7.43	77	185
	10/17/16-10/18/16	Yes	10.2	2.3	1.2	7.9	<0.5	<7	<10	7.13	N/R	134
	11/28/16-11/29/16	Yes	11.7	2.4	<0.1	9.3	<0.5	9	48.4	6.98	57	99
	12/12/16-12/13/16	Yes	13.6	1.4	<0.5	12.2	<0.5	<5	<10	6.93	N/R	93.2
SDS#24/25	9/26/16 - 9/27/16	No	7	3.5	0.9	3.5	<0.5	11	12	7.31	73	176.2
	10/17/16-10/18/16	No	13.8	6.9	4.9	6.9	<0.5	20	10	7.33	N/R	182
	11/28/16-11/29/16	No	33.8	<1	<0.5	33.8	<0.5	<5	<10	6.84	N/R	54.4
	12/12/16-12/13/16	No	52.3	<1	<0.5	52.3	<0.5	<5	<10	6.36	N/R	29.8
SDS#19	8/22/16 - 8/23/16	Yes	2.3	<1.0	<0.5	2.3	<0.5	<11	<10	7.43	78	222
	9/19/16-9/20/16	Yes	7.7	2	0.8	5.7	<0.5	10	10	7.28	76	200
	10/17/16-10/18/16	Yes	7.7	2.3	0.8	5.4	<0.5	8	<10	7.14	N/R	192
	11/28/16-11/29/16	Yes	10.6	3.2	0.7	7.4	<0.1	7	6.4	7.02	57	125
	12/5/16-12/6/16	Yes	11.1	1.5	<0.5	9.6	<0.5	8	<10	7.09	56	107.6



SDS#17	11/14/16-11/15/16	Yes	16.6	1.5	1.1	15.1	<0.5	7	<10	6.74	59	114
	12/5/16-12/6/16	Yes	40.4	3.1	1.1	37.3	<0.5	<5	11.6	6.55	54	40.8
SDS#14	11/14/16 - 11/15/16	Yes	35.4	9.9	8.3	25.5	<0.5	<5	<10	6.74	50	133
	12/5/16 - 12/6/16	Yes	28.9	18	17.4	10.9	<0.5	9	<10	6.92	53	147.2
Average			17.56	4.243	3.427273	14.2556	<0.5	9.8	16.93	7.0417	64.25	131.733

Note: The TN average for Hydrokinetic during the Pilot Demonstration was 17.4 mg/l calculated using all TN results labeled as "Yes" under the "Calculate" Column.

Table 11 - Norweco Hydro-Kinetic Provisional Sample Results

SITE	Sample Date	TN(mg/l) (6)	TKN (mg/l)	Ammonia (as N)	NO3 (Nitrate as N)	NO2 (Nitrite as N)	BOD	TSS	PH	Temp	Alk
PS# 1/	8/2/2017	7.4	7.4	6.71	< 1	< 0.5	N/A	N/A	6.9	N/A	N/A
SDS# 4	10/30/2017	31	31	28.9	< 0.05	< 0.05	< 3	27	6.84	18.3	250
	11/22/2017	25.6	22.7	N/A	2.9	< 0.5	N/A	N/A	N/A	N/A	N/A
PS# 2/	8/2/2017	13.3	1.7	< 0.5	11.6	< 0.5	N/A	N/A	6.8	N/A	N/A
SDS# 24/25	10/30/2017	10.9	2.23	< 0.05	8.66	< 0.05	< 3	< 10	7.27	17.3	130
	11/22/2017	26.1	2.4	N/A	23.7	< 0.5	N/A	N/A	N/A	N/A	N/A
PS# 3/	8/2/2017	14.6	< 0.5	0.63	14.6	< 0.5	N/A	N/A	6.9	N/A	N/A
SDS# 19	10/30/2017	35.4	1.08	< 0.05	34.3	< 0.05	< 3	< 10	7.1	18.4	80
	11/2/2017	33.6	0.6	N/A	33	< 0.5	N/A	N/A	N/A	N/A	N/A
PS# 4/	8/2/2017	10.6	3	1.13	7.6	< 0.5	N/A	N/A	6.9	N/A	N/A
SDS# 17	10/30/2017	11.3	2.59	< 0.05	8.75	< 0.05	< 4	< 10	7.25	19.2	220
	11/22/2017	11.8	1.8	N/A	10	< 0.5	N/A	N/A	N/A	N/A	N/A
PS# 5/	8/3/2017	56.9	54.9	59.83	2	< 0.5	N/A	N/A	6.8	N/A	N/A
SDS# 14	10/30/2017	17	3.66	1.35	13.2	0.133	< 3	< 4	6.57	16.5	64
	11/8/2017	18.1	2.2	N/A	15.9	< 0.5	N/A	N/A	N/A	N/A	N/A
Average		22.2	10.2	5.43	12.16	0.35	3.3	14	6.995	18.3	170



2.4.5. Orenco AX Series

The Orenco AX series is a prepackaged packed bed media filter that is contained in a fiberglass container that is installed after a two-compartment septic tank. A pump basin in the second compartment of the septic tank distributes effluent to the treatment unit where it is nitrified. Effluent trickles through the media collects at the bottom of the treatment unit where it flows by gravity back to the inlet end of the septic tank for denitrification. When the level in the septic tank reaches peak level a valve seals off the recirculation and sends treated effluent to a separate chamber where it is then discharged to the leaching structure.

Three (3) Orenco AX systems have been installed as part of the Septic Demonstration Program. Only two out of the three were at equilibrium in 2017. The composite sampling of these systems from November 2016 to December 2017 averaged 25.6 mg/L. There is currently not enough data to issue approval at this time.

Table 12 - Orenco AX Series Steady State 24-Hour Composite Sample Results

Site #	Sample Date	TN (mg/l)	TKN (mg/l)	Ammonia (as N)	NO3 (Nitrate as N)	NO2 (Nitrite as N)	BOD	TSS	PH	Temp	Alk
SDS#13	11/14/16-11/15/16	23.9	8	4.2	15.2	0.7	10	< 10	6.64	54	37
	12/12/16-12/13/16	51.3	37.1	5.2	14.2	0.7	182	##	6.84	55	65.6
	2/6/17-2/7/17	33.2	23.4	9.8	9.8	< 0.5	93	< 10	6.81	53	124
	3/20/17-3/21/17	19.9	11.9	8.1	8	< 0.5	18	12	6.86	51	90
	4/24/17-4/25/17	14.1	11	10.7	2.2	0.9	42	16	7.14	NR	113
	6/26/17-6/27/17	14.9	7	6	7	0.9	22	< 10	7.07	71.9	105
	8/14/17-8/15/17	15.8	3.8	4.9	12	< 0.5	14	11	7.44	72.1	105
	8/28/17-8/29/17	16.9	5.2	5.7	11.7	< 0.5	11	5	7.16	69.8	113
	10/2/17-10/3/17	14.7	3.5	2.6	11.2	< 0.5	9	< 20	7.46	69.8	130
	11/13/17-11/14/17	11.4	1.2	3.6	10.2	< 0.5	9	< 10	7.29	62.1	106
12/11/17-12/12/17	15.1	7.5	4.2	7.6	< 0.5	19	7	6.96	56.5	66	
SDS # 34	8/28/17-8/29/17	24.2	8.7	5.7	10	5.5	< 5	< 5	6.4	74.7	38
	10/2/17-10/3/17	20.9	2.4	2.3	18.5	< 0.5	< 5	< 10	6.2	73.4	17
	11/13/17-11/14/17	44.9	40.5	42.2	4.4	< 0.5	7	< 10	7.13	65.7	203
	12/11/17-12/12/17	63.4	54.4	44.7	8.1	0.9	94	###	6.9	63	211
	Average	25.6	15.0	10.6	10.0	0.94	36	47	7.0	63.7	101



2.4.6. BUSS GT

The Busse System is installed above grade, in non-living areas of the house such a garage or basement. The fiberglass tanks have four compartments, the first for settling, second for aeration, third for settling and final compartment for membrane filtration.

There are two (2) Busse systems that were installed as part of the demonstration program. Both systems were taken off line in the spring of 2016 due to non-performance, most notably, an effluent pH of less than 4 in both systems. Site SDS#7 was briefly turned back on from June 19, 2017 to July 25, 2017 and the performance did not improve. The manufacturer is currently working with local engineers to reconfigure the system and treatment process. The monitoring of these systems may resume in 2018. The average performance of the system was 83.1 mg/L as of December 31, 2017.

Table 13 - Busse GT Steady State 24-Hour Composite Sample Results

Site #	Sample Date	TN (mg/l)	TKN (mg/l)	Ammonia (as N)	NO3 (Nitrate as N)	NO2 (Nitrite as N)	BOD	TSS	PH	Temp	Alk
SDS#7	3/28/16 - 3/29/16	58.6	33.9	1.1	24.7	< 0.5	NR	NR	5.49	NR	NR
	4/18/16 -4/19/16	102.4	34.3	29	68.1	< 0.5	< 8	< 10	4.08	64	NR
	5/16/16-5/17/16	76.3	27.3	22.3	48.9	< 0.5	< 10	< 10	NR	59.8	NR
	6/20/16 - 6/21/16	108.2	46.7	28.9	61.5	< 0.5	NR	< 10	3.84	NR	NR
	8/15/16 - 8/16/16	13.4	13.4	15.3	< 0.5	< 0.5	< 7	< 10	3.57	80	NR
	9/19/16 - 9/20/16	80.8	30.2	26.9	50.6	< 0.5	7	< 10	3.7	72	NR
	10/3/16-10/4/16	70.1	22.7	17.3	47.4	< 0.5	8	10	3.62	74	NR
	6/19/17-6/20/17	113.1	6.1	4	107	< 0.5	< 5	< 10	3.5	71.96	NR
	7/24/17-7/25/17	140	NR	7.3	140	< 0.5	NR	NR	NR	73.4	NR
	SDS#3	9/26/16 - 9/27/16	68.5	16.8	20.9	51.7	< 0.5	7	< 10	3.68	74

2.4.7. Phase II - Septic Demonstration Systems:

Based upon the success of Phase I of the Demonstration Program, Suffolk County issued an RFEI for a Phase II Demo Program in which a total of 20 systems were donated from 6 manufacturers representing 8 different technologies. On July 26, 2016, 20 homeowners were selected from a lottery. Installations for these systems began in November 2016 and should be completed by the end of 2017.

Figure 2 depicts the systems included in Phase II.



Figure 2 - Phase II Demonstration I/A OWTS Technologies

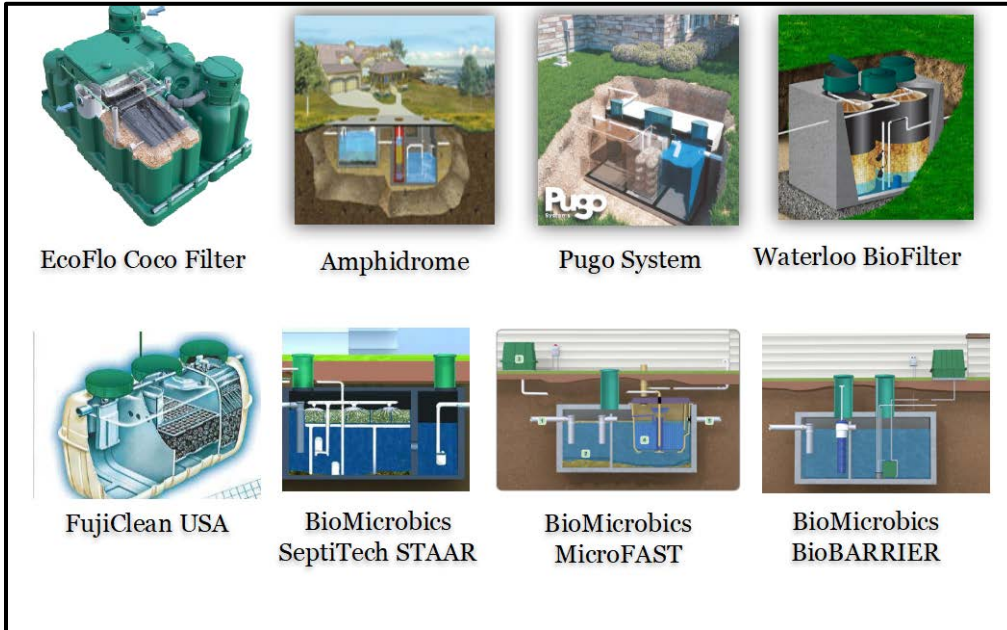

2.4.8. Amphidrome

Amphidrome is a multi-tank system utilizing a biologically active filter operating as a sequencing batch reactor. Sewage first enters a septic tank to allow for settling and separation. Liquid wastewater flows by gravity from the septic tank into the reactor where it moves through layers of gravel and sand and receives aeration via an external blower. Wastewater continues through the reactor into the clearwell tank containing two submersible pumps. When the first submersible pump cycles on it pushes wastewater backward through the system; back flowing up through the reactor and recirculating back to the septic tank. When the submersible pump cycles off, the wastewater moves again by gravity forward through the system and into the clearwell tank. The second submersible pump in the clearwell tank moves final effluent to discharge.

There were two (2) Amphidrome Systems installed between February and June of 2017 as part of Phase 2 of the Septic Demonstration Program. The average of the Amphidrome System at equilibrium was 17.8 mg/L. However, there was not enough data to grant Provisional Use Approval in 2017.

Table 14 - Amphidrome Steady State 24-Hour Composite Sample Results

Site #	Sample Date	TN (mg/l)	TKN (mg/l)	Ammonia (as N)	NO3 (Nitrate as N)	NO2 (Nitrite as N)	BOD	TSS	PH	Temp	Alk
SDS#28	6/19-17-6/20/17	9.5	6.1	1.2	< 0.5	3.4	12	12	7.61	68.3	183
	7/24/17-7/25/17	9.9	1.8	< 0.5	8.1	< 0.5	< 5	7	7.53	73.4	NR



	8/21/17-8/22/17	5.7	3.6	<	0.5	2.1	<	0.5	12	31	7.65	78.0	NR			
	10/4/17-10/5/17	15.5	2.2	<	0.5	13.3	<	0.5	NA	NA	NA	73	NA			
	10/30/17-10/31/17	11.9	<	1	<	1	11.9	<	0.5	6	12	7.16	63.9	46		
	12/4/17-12/5/17	24.4	<	0.5		0.8	24.4	<	0.5	<	5	<	10	NR	54.9	NR
SDS#35	10/2/17-10/3/17	18.8	1.5	<	0.5	17.3	<	0.5	7	<	10	7.27	74.5	48		
	11/13/17-11/14/17	18.1	1.8	<	0.5	16.3	<	0.5	7	<	10	7.49	66.4	64		
	12/11/17-12/12/17	46.1	46.1		34.2	<	0.5	<	0.5	>	168	26	7.24	63.9	212	
	Average	17.8	7.2		4.4	10.5	0.82		28	15	7.42	68.5	110			

2.4.9. Ecoflo Coco Filter

Ecoflo Coco Filter is a trickling media filter comprised of multiple tanks. The first tank is a baffled septic tank for settling and separation of incoming sewage. The liquid wastewater moves through an effluent filter and then to the Ecoflo Coco Filter. In the filter unit a tipping weir evenly disperses incoming wastewater over a thick bed of coconut husks. The wastewater is treated by the bacteria living on the coconut husks as it moves downward through the media and is then collected at the bottom of the unit. A submersible pump in the filter unit moves the collected wastewater through a splitter valve which allows some water to be recirculated back to the septic tank and some to be moved to a sulfur polishing unit. The wastewater that is pumped to the sulfur polishing unit moves by gravity through the sulfur media and finally out to discharge.

There were two (2) Ecoflo Coco Filter Systems installed between November 2016 and February 2017 as part of Phase 2 of the Septic Demonstration Program. Ecoflo also installed a denitrification polishing filter following the treatment unit to remove excess nitrate from the effluent. Suffolk County took composite samples before and after the secondary denitrification unit. The average of Ecoflo Coco Filters at equilibrium was 19.8 mg/L in 2017 and the average after the denitrification unit was 7.1 mg/L. However, there was not enough data to grant Provisional Use Approval in 2017.

It is noted that Site SDS#9 was installed on November 10, 2016 but had a failure of the dosing weir and the system was restarted on July 25, 2017.

Table 15 - EcoFlo Coco Filter Steady State 24-Hour Composite Sample Results

Site #	Sample Date	TN (mg/l)	TKN (mg/l)	Ammonia (as N)	NO3 (Nitrate as N)	NO2 (Nitrite as N)	BOD	TSS	PH	Temp	Alk
SDS#9	9/25/17-9/26/17	44.8	37.2	34.2	7.6	< 0.5	32	25	7	71.8	244
	10/30/17-10/31/17	37.3	20.2	23	17.1	< 0.5	33	13	7.26	67.1	236
	12/4/17-12/5/17	NR	NR	2.2	9.6	< 0.5	22	< 3	7.11	57.6	296



SDS#8	6/5/17-6/6/17	10.8	1	<	0.5	9.8	<	0.5	<	5	12	6.92	60.98	241		
	7/10/17-7/11/17	13	3.6		1.1	9.4	<	0.5	<	5	<	10	7.05	75.92	202	
	8/7/17-8/8/17	2.4	2.4		1.4	<	0.5	<	0.5	<	5	8	6.95	73.22	196	
	9/11/17-9/12/17	19.3	1.3	<	0.5	18	<	0.5	<	5	<	5	7.04	70.2	127	
	10/16/17-10/17/17	16	<	0.5	<	0.5	16	<	0.5	<	5	<	5	6.92	67.3	122
	11/20/17-11/21/17	15.1	1.4		0.5	13.7	<	0.5	<	5	<	10	7.42	62.4	106	
	Average	19.8	8.4		7.1	11.3		0.5		13	10	7.074	67.39	196		

* System restarted 7/25/17- system failure due to broken balancing foot on dosing weir

Table 16 - EcoFlo Coco Filter with Additional Denitrification Filter Steady State

Site #	Sample Date	TN (mg/l)	TKN (mg/l)	Ammonia (as N)	NO3 (Nitrate as N)	NO2 (Nitrite as N)	BOD	TSS	PH	Temp	Alk					
SDS#9	10/30/17-10/31/17	20	20	24.4	<	0.5	<	0.5	15	11	7.31	67.1	267			
	12/4/17-12/5/17	27.2	27.2	21.7	<	0.5	<	0.5	<	7	8	7.19	57.6	333		
SDS#8	6/5/17-6/6/17	1.1	1.1	<	0.5	<	0.5	<	0.5	<	5	12	7.18	60.98	343	
	7/10/17-7/11/17	1.3	1.3	1	<	0.5	<	0.5	<	5	<	10	7.28	75.92	294	
	8/7/17-8/8/17	1.5	1.5	1.4	<	0.5	<	0.5	<	5	<	5	7.27	73.22	271	
	9/11/17-9/12/17	1.1	1.1	0.6	<	0.5	<	0.5	<	5	<	5	7.48	70.2	235	
	10/16/17-10/17/17	0.8	0.8	<	0.5	<	0.5	<	0.5	<	5	<	5	7.54	67.3	244
	11/20/17-11/21/17	4	2.3	1.3	1.7	<	0.5	<	5	<	10	7.57	62.4	157		
	Average	7.1	6.9	6.4	0.65	0.5	6.5	8	7.35	66.8	268					

* System restarted 7/25/17- system failure due to broken balancing foot on influent dispersal weir

2.4.10. Pugo System

Pugo is a self-contained, extended aeration and contact filtration unit consisting of three chambers. In the primary chamber sewage separates and settles allowing liquid wastewater to flow through and solids to sink to the bottom where they are subject to anaerobic digestion. Liquid wastewater then enters the aeration chamber where it is circulated via aeration from an external blower through plastic media harboring microbes which will metabolize and remove nutrients from the wastewater. An air lift pump powered by the same external blower recirculates aerated wastewater back to the primary chamber to



complete denitrification. Wastewater flows by gravity into the third and final clarifying chamber where settling of any residual solids occurs and final effluent is discharged.

There were four (4) Pugo Systems installed between January and March of 2017 as part of Phase 2 of the Septic Demonstration Program. The average of Pugo at equilibrium was 23.7 mg/L in 2017 and there was not enough of a dataset to grant Provisional Use Approval in 2017.

It is noted that Site SDS#29 was restarted on 9/27/2017 due to the system failure suspected to be due to the homeowners use of essential oils.

Table 17 - Pugo Steady State 24-Hour Composite Sample Results

Site #	Sample Date	TN (mg/l)	TKN (mg/l)	Ammonia (as N)	NO3 (Nitrate as N)	NO2 (Nitrite as N)	BOD	TSS	PH	Temp	Alk
SDS#1	6/19/17-6/20/17	22.5	6.1	3.7	16.4	< 0.5	18	17	6.99	73.76	32
	7/24/17-7/25/17	20.8	19.8	21.8	1	< 0.5	31	21	7.61	77	NR
	8/21/17-8/22/17	24.4	24.4	20.5	< 0.5	< 0.9	53	23	7.44	82.4	NR
	9/25/17-9/26/17	24.7	24.7	22.6	< 0.5	< 0.5	64	33	7.24	79.3	76
	10/30/17-10/31/17	30.4	28.6	31.3	1.8	< 0.5	29	13	7.69	72	188
	12/4/17-12/5/17	31	31	31.3	< 0.5	< 0.5	24	26	7.47	64	195
SDS#20	5/8/17-5/9/2017	22	< 1	< 0.5	< 0.5	22	12	< 10	7.21	62.42	51.5
	6/12/17-6/13/17	33.2	< 1	< 1	32.2	1	15	< 10	7.16	70.34	NR
	7/17/17-7/18/17	17.5	1.9	< 1	15.6	< 0.5	7	< 10	7.53	73.76	93.4
	8/21/17-8/22/17	24.1	2.8	0.5	20.1	1.2	14	6	7.29	77.9	NR
	9/25/17-9/26/17	31.2	6.6	2.1	23.4	1.2	36	37	7.32	76.3	150
	10/30/17-10/31/17	20.9	< 1	1.1	20.9	< 0.5	18	21	7.16	67.1	48
11/27/17-11/28/17	NR	NR	27.1	20.1	< 0.5	20	9	6.65	60.6	NR	
SDS#5	5/8/17-5/9/17	9.3	< 1	0.5	3.8	5.5	< 7	16	7.15	68.36	NR
	6/12/17-6/13/17	15.3	1.1	< 1	14.2	< 0.5	< 5	< 10	NR	77.54	NR
	7/17/17-7/18/17	41.7	18	15.9	23.7	< 0.5	18	79	6.71	79.88	33
	9/18/17-9/19/17	22.7	20.2	15.8	2.5	< 0.5	45	75	7.07	77.7	36.4



	10/23/17-10/24/17	37.1	16.1	0.6	21	<	0.5	9	23	6.64	70.5	NR				
	11/27/17-11/28/17	NR	NR	5.6	20.8	<	0.5	14	9	6.46	59.5	NR				
SDS#29*	10/16/17-10/17/17	19.8	<	0.5	<	0.5	19.8	<	0.5	<	5	<	5	6.64	70.3	15
	11/20/17-11/21/17	2.9	2.9	<	0.5	<	0.5	<	0.5	<	5	<	10	6.5	59.9	11
	Average	23.7	11.0	9.8	12.4	1.9	21	22	7.10	71.5	77.4					

* System restarted 9/27/2017- system failure suspected to be due to homeowner introduction of essential oils

2.4.11. FujiClean CEN Series

FujiClean is a self-contained, extended aeration and contact filtration treatment unit consisting of three chambers. The first sedimentation chamber allows for pretreatment of influent via settling and separation. Liquids then move by gravity to the anaerobic chamber where it comes in contact with a submerged media that allows for colonization of bacteria to aid in nitrate denitrification. In the final chamber aerobic contact filtration occurs via an external air blower and a submerged media. The same air blower also powers air lift pumps which recirculate sludge and water from the last chamber back to the first chamber and pumps final effluent out to discharge.

There were four (4) FujiClean CEN Systems installed between March and June of 2017 as part of Phase 2 of the Septic Demonstration Program. The systems were sampled from June 2017 through November 2017 and averaged 17.8 mg/L TN. The dataset of 75% of the systems maintained an average of 16.6 mg/L TN. FujiClean will be recommended for Provisional Use Approval in early 2018.

Table 18 - FujiClean CEN Series Steady State 24-Hour Composite Sample Results

Site #	Sample Date	TN (mg/l)	TKN (mg/l)	Ammonia (as N)	NO3 (Nitrate as N)	NO2 (Nitrite as N)	BOD	TSS	PH	Temp	Alk				
SDS #30	7/31/17-8/1/17	9.9	1.8	<	0.5	7.3	0.8	10	19	7.25	78.98	98			
	8/28/17-8/29/17	71.4	70.5	68.7	<	0.5	0.9	24	27	?318?	76.8	N/R			
	10/2/17-10/3/17	27.6	27.6	25.4	<	0.5	<	0.5	47	22	7.67	183			
	11/13/17-11/14/17	16.6	5.8	<	0.5	10.8	<	0.5	<	5	<	10	7.41	59.9	86
	12/11/17-12/12/17	10.7	1.2	<	0.5	8.9	0.6	<	5	<	5	7.24	52.9	74	
SDS #31	6/26/17-6/27/17	25.6	24.8	23.9	<	0.5	0.8	54	42	7.56	75.2	197			
	7/31/17-8/1/17	4.3	1.4	1	2.1	0.8	<	5	<	10	7.48	78.26	138		
	8/28/17-8/29/17	8.7	3.8	<	0.5	1.6	3.3	11	8	7.49	73.9	96			

2017 Annual Technology Review
 Innovative & Alternative Onsite Wastewater Treatment Systems



	10/2/17-10/3/17	5.8	4.5	<	0.5	1.3	<	0.5	13	13	7.66	69.4	122			
	11/13/17-11/14/17	8.5	0.9	<	0.5	7.6	<	0.5	6	< 10	7.5	55.9	83			
	12/11/17-12/12/17	19.9	19.2		18.5	<	0.5	0.7	16	<	5	7.66	52.5	167.4		
SDS #32	6/26/17-6/27/17	27.7	26.7		17.5	<	0.5	1	23	12	7.49	73.4	159			
	7/31/17-8/1/17	4.1	1.9	<	0.5	<	0.5	2.2	9	13	7.77	77.36	229			
	8/28/17-8/29/17	17.1	13.8		4.3	<	0.5	3.3	77	52	6.96	74.7	99			
	10/2/17-10/3/17	11.6	6.3	<	0.5	4.8		0.5	21	10	7.63	72.1	80			
	11/13/17-11/14/17	4.1	2.9	<	0.5	1.2	<	0.5	19	14	8.17	53.8	NR			
	12/11/17-12/12/17	3.2	1.4	<	0.5	1.8	<	0.5	6	<	5	7.46	52	160		
SDS #36	7/10/17-7/11/17	23.8	2.1	<	0.5	21.7	<	0.5	6	<	10	7.63	76.28	88		
	8/7/17-8/8/17	33	1.1		1.5	31		0.9	21	44	7.12	72.14	53			
	9/11/17-9/12/17	4.7	3.1	<	0.5	1.6	<	0.5	<	5	<	5	7.48	66.9	54	
	10/16/17-10/17/17	23.4	<	0.5	<	0.5	23.4	<	0.5	<	5	<	5	6.56	65.7	14.4
	11/20/17-11/21/17	17.7	2.2	<	0.5	15.5	<	0.5	<	5	<	10	7.01	56.1	28	
	12/18/17-12/19/17	29.9	1.3	<	0.5	28.6	<	0.5	21	65	6.4	50.2	NR			
	Average	17.86	9.77		7.3	7.5		0.93	18	18	7.39	66.67	110			

2.4.12. Waterloo Biofilter

Waterloo Biofilter is a packed bed media filter comprised of multiple tanks. Raw sewage flows from the building into a septic tank with digester where solids are separated from liquids. After gravity flowing into the pump tank, wastewater is time dosed over the biofilter in the treatment tank by a submersible pump. Wastewater is absorbed by and trickles downward through foam media which provides both physical filtration and biological treatment via inhabitant microbes. Treated wastewater is collected at the bottom of the treatment tank where a submersible pump moves it through the piping manifold which splits the flow between the alkalinity tank and sulfur polishing tank. The wastewater that is pushed to the alkalinity tank is conditioned prior to recirculation into the primary septic tank. The remainder of the wastewater is pumped to the polishing unit where sulfur contact further reduces nitrogen levels prior to final effluent discharge.



There were two (2) Waterloo Biofilter Systems installed May 2017 as part of Phase 2 of the Septic Demonstration Program. Waterloo also installed a denitrification polishing filter following the treatment unit to remove excess nitrate from the effluent, this secondary denitrification unit will be sampled in 2018. The average of Waterloo Biofilter at equilibrium was 54.4 mg/L in 2017. SCDHS will work with manufacturer in 2018 to try to improve overall performance of the two systems.

Table 19 - Waterloo Biofilter Steady State 24-Hour Composite Sample Results

Site #	Sample Date	TN (mg/l)	TKN (mg/l)	Ammonia (as N)	NO3 (Nitrate as N)	NO2 (Nitrite as N)	BOD	TSS	PH	Temp	Alk
SDS #37	8/14/17-8/15/17	23.9	17.5	22.8	5.7	0.7	14	< 10	7.04	79.88	223
	9/18/17-9/19/17	31.6	22.1	23	8.7	0.8	15	10	7.09	74.1	NR
	10/23/17-10/24/17	31.7	16.3	17.7	15.4	< 0.5	14	7	7.07	70.9	188
	11/27/17-11/28/17	38.6	29.5	22.8	8.6	0.5	18	9	6.96	59.5	203
SDS #38	7/17/17-7/18/17	82.5	79	83	3.5	< 0.5	19	14	7.33	80.42	450
	8/14/17-8/15/17	84.5	81	90.1	3.5	< 0.5	12	< 10	7.42	77.54	455
	9/18/17-9/19/17	74.9	62.4	12.5	11.4	1.1	7	6	7.43	75.2	376
	10/23/17-10/24/17	53.5	39.6	39.4	13.9	< 0.5	NR	NR	NR	70.2	NR
	11/27/17-11/28/17	68.3	48.9	36.5	19.4	< 0.5	5	< 5	7.22	58.6	258
	Average	54.4	44.0	38.6	10.0	0.6	13	9	7.20	71.82	307

2.4.13. BioMicrobics BioBarrier

BioBarrier is a membrane bioreactor consisting of two tanks. The first tank allows for settling and separation of incoming sewage with liquid wastewater moving through an effluent filter to prevent large solids from entering the treatment tank. Next liquid wastewater moves into the first chamber of the treatment tank, known as the anoxic zone, where a low oxygen mixed liquor is maintained by an external mixing blower. Wastewater then flows to the second chamber, known as the aerobic zone, where the reactor unit is submerged. A second external blower piped to the reactor unit creates an upward flow between membrane plates providing vigorous scouring action. Wastewater is passed through the membranes for microfiltration and ultrafiltration processes to produce the final effluent which is pumped to discharge.

There were two (2) BioBarrier MBR Systems installed between May and June of 2017 as part of Phase 2 of the Septic Demonstration Program. The systems averaged 49.7 mg/L and SCDHS will work with the Manufacturer to try and improve the performance of these systems in 2018.



Table 20 - BioBarrier Steady State 24-Hour Composite Sample Results

Site #	Sample Date	TN (mg/l)	TKN (mg/l)	Ammonia (as N)	NO3 (Nitrate as N)	NO2 (Nitrite as N)	BOD	TSS	PH	Temp	Alk
SDS #39	7/24/17-7/25/17	63.9	5.8	19.2	58.1	< 0.5	33	8	6.83	75.2	NR
	8/21/17-8/22/17	61	14.5	14.5	44.9	1.6	33 < 5	6.08	79.16	NR	
	10/4/17-10/5/17	69.8	18	18.8	51.8	< 0.5	NA	NA	NA	70.2	NA
	10/30/17-10/31/17	N/A	NR	20.9	47.9	< 0.5	< 6 < 10	6.42	65.1	NR	
	12/4/17-12/5/17	60.6	29.3	29.5	31.3	< 0.5	< 5 < 3	7.43	48.6	112	
SDS #40	7/17/17-7/18/17	22.74	3.74	4.1	1	18	< 5 < 10	6.92	78.8	32	
	8/14/17-8/15/17	36.2	9.1	10.2	20.9	6.2	< 5 < 10	6.88	76.64	18	
	9/18/17-9/19/17	33.7	9.1	8.9	24.6	< 0.5	< 5 < 10	5.32	73.8	NR	
	10/23/17-10/24/17	N/A	NR	3.5	20.9	< 0.5	< 5 < 10	6.28	69.1	6.28	
	Average	49.7	12.8	14.4	33.5	3.2	12	8	6.52	70.73	42

2.4.14. BioMicrobics SeptiTech STAAR

SeptiTech STAAR is a trickling filter comprised of two tanks. The first tank is a baffled septic tank for settling and separation of incoming sewage. Wastewater from the primary septic tank flows into the bottom of the second tank, mixing with already treated wastewater. A pump at the bottom of the second tank moves wastewater upward and through sprayers which both aerate and disperse the wastewater onto the filter media. As wastewater moves through the filter media it is treated by inhabitant microbes and then moves by gravity back to the tank below mixing with newly incoming wastewater from the primary septic tank and previously treated water. A portion of the treated wastewater along with sludge that accumulates at the bottom the filter tank is recirculated back to the primary septic tank for denitrification. A submersible pump located in the second chamber of the filter tank moves the final effluent to discharge.

There were two (2) SeptiTech STAAR Systems installed in December of 2017 as part of Phase 2 of the Septic Demonstration Program. There is no steady-state data to report as of December 31, 2017.

2.4.15. BioMicrobics MicroFAST

MicroFAST is a two-tank fixed activated sludge treatment system. The first tank is a baffled septic tank for settling and separation of incoming sewage. Wastewater from the septic tank flows into a secondary treatment tank consisting of a fixed film aeration unit that receives oxygen from an external blower 24/7. Following the aeration unit is a clearwell with a recirculation pump that sends effluent back to the headworks of the septic tank for denitrification. Final effluent can be dispersed to leaching by pump or gravity.



Two (2) MicroFAST Systems are anticipated to be installed in 2018 as part of Phase 2 of the Septic Demonstration Program.

2.5. Commercial Systems

Two commercial systems were sampled in 2017. An Orenco AX-MAX system is installed at Meschutt Beach in Hampton Bays and a vegetated recirculating gravel filter is installed at Sylvester Manor Educational Farm on Shelter Island. Both systems are performing below the nitrogen standard of 19 mg/L total nitrogen as illustrated in the below tables.

Table 21 - Orenco AX-MAX at Meschutt County Park

Manufacturer	Sample Date	Calculate (Yes or No) (5)	TN(mg/l) (6)	TKN (mg/l)	Ammonia (as N)	NO3 (Nitrate as N)	NO2 (Nitrite as N)	BOD	TSS	PH	Temp	Alkalinity	
Orenco Advantex AX-MAX Unit	7/25/16 - 7/26/16	Yes	18.1	17.2	9.5	0.9	< 0.5	35	37	7.37		133.2	
	8/22/16 - 8/23/16	Yes	20.1	20.1	18.6	< 0.5	< 0.5	125	88	7.33	78	183.4	
	9/26/16 - 9/27/16	Yes	14.1	< 0.5	< 0.5	14.1	< 0.5	8	10	7.29	74	51.8	
	6/5/17-6/6/17	Yes	8	1	< 0.5	7	< 0.5	< 5	< 10	8.03	63.68	213	
	7/10/17-7/11/17	Yes	24.5	7.9	4	3.7	12.9	< 10	9	6.74	79.16	37.4	
	8/7/17-8/8/17	Yes	16	6	9.9	10	< 0.5	7	< 5	7.09	80.06	83	
	9/11/17-9/12/17	Yes	20.8	13.6	4.3	6.1	< 0.5	18	48	7.07	73.4	84	
	10/16/17-10/17/17	Yes	15.5	15.5	19.9	< 0.5	< 0.5	< 5	< 5	7.76	62.2	200	
			AVERAGE	17.1375	10.225	8.4	5.35	2.05	26.625	26.5	7.335	72.92857	123.225

Table 22 - Vegetated Recirculating Gravel Filter at Sylvester Manor

Manufacturer	Sample Date	Calculate (Yes or No) (5)	TN(mg/l) (6)	TKN (mg/l)	Ammonia (as N)	NO3 (Nitrate as N)	NO2 (Nitrite as N)	BOD	TSS	PH	Temp	Alkalinity
Vegetated Gravel Recirculating Filter	8/7/17-8/8/17	Yes	18	< 0.5	< 0.5	18	< 0.5	< 5	< 5	7.41	75.38	154
	9/11/17-9/12/17	Yes	16.4	1.4	< 0.5	15	< 0.5	< 5	< 5	7.56	71.1	175
	10/16/17-10/17/17	Yes	9.1	1	< 0.5	8.1	< 0.5	< 5	< 5	7.6	66.4	177
		AVERAGE	15.2275	4.6	5.35	10.4	0.5	5	5	7.533	69.60171	165.845



3. CENTER FOR CLEAN WATER TECHNOLOGY

This section provides report on the efforts of the NYS CCWT. *CCWT has taken the liberty of including a report of our activities through December 2018 even though technically this report is prepared for 2017.*

3.1. Overview

New York State has established the New York State Center for Clean Water Technology at Stony Brook University. The Research and Development Program funded by the State and launched by the Center is focused on the development of cost-effective methods for reducing the impacts of nitrogen and other contaminants to ground and surface waters caused by cesspools, septic systems and other sources. Integral to the formation and function of the Center are three inter-related goals:

1. Strategic planning to maximize impact of research activities and investments;
2. Development of affordable and effective I/A OWTS and other methods that will protect groundwater from contamination;
3. Establishment of a program for Outreach and Business Development to catalyze the creation of new business focused on clean water technology in the region that will also create jobs in the field of advanced onsite treatment of wastewater.

The beginning of the 2017 – 2018 work plan (year two of the simplified renewal agreement) has seen a series of fundamental insights, breakthroughs, and accomplishments for the Center. Key highlights of this past year include:

- Extensive data collection and analyses from pilot installations at the Massachusetts Alternative Septic System Testing Center (MASSTC);
- Functioning of Nitrogen Removing Biofilters (NRBs) continues to be elucidated, including: “woodchip box” system development, microbial characterization revealed clear insights into denitrification, and low greenhouse gas emissions;
- In 2018 the Center completed construction of five (5) NRB experimental systems in Suffolk County pursuant to the requirements of Article 19 of the Suffolk County Sanitary Code;
- Development of strategic partnerships with industry professionals and environmental advocacy groups to leverage resources;
- New lab and office space pledged to the Center in the Innovation and Discovery Center;
- Center labs obtained New York State Environmental Laboratory Approval Program (ELAP) certification for all nitrogen species, BOD, TSS, alkalinity, phosphorus species, and total organic carbon;
- Substantial completion of the CCWT Wastewater Research and Innovation Facility (WRIF) and started the planning of the its expansion for full-scale pilot installations;
- Significant advances in the design and installation of other I/A systems including pressurized shallow drainfields (PSDs), permeable reactive barriers (PRBs), constructed wetlands (CWs), and high-flux cellulose membranes;
- A lab-scale prototype membrane bioreactor is now operational and being used to examine novel microbial pathways for denitrification;



- Novel nanocellulose membrane materials have been successfully synthesized and show superior performance to traditional membrane materials;
- Assisted The Nature Conservancy with the design of a Wetlands Treatment System at their Upland farms site;
- Assisted the Town of Brookhaven with a grant application for the installation of a Permeable Reactive Barrier for the bulkhead replacement at their Davis Park facility;
- Preparation of a Guidance Document for the design and installation of wetlands treatment systems;
- And, development of CCWT's next generation of NRBs (a.k.a. NRB 2.0).

In 2018 CCWT has hired a full-time professional engineer as program manager to oversee the installation of the full-scale experimental pilot systems, assist our researchers in the development of the next generation of NRBs, manage the construction of the WRIF, provide oversight of engineering consultants retained by CCWT to design and prepare I/A OWTS construction documents, collaborate with the Suffolk County Department of Health Services and other OWTS professionals to refine the designs to lower installation costs, assist in the preparation of NYSDEC report documents and grant applications, operation of installed NRB systems, and general management of the wastewater side of CCWT.

Finally, Dr. Harold W. Walker, P.E., one of CCWT's co-directors, has left Stony Brook University in 2018. He has joined our Executive Committee and, in this capacity, will continue to contribute to the research of NRBs and other nitrogen removing processes. CCWT has reorganized duties to internal staff to be able to continue the I/A OWTS research work. Currently, there are no plans to replace Dr. Walker, but the revised organizational structure is designed to efficiently take advantage of Dr. Walker's consultant role.

3.2. First Generation Nitrogen Removing Biofilter (NRB 1.0)

The CCWT process of developing a cost efficient and passive nitrogen removing onsite wastewater treatment system has evolved since inception. CCWT is actively enhancing the design of the first generation of NRBs in order to substantially reduce the cost of installation. CCWT has come to call the first generation of NRBs "NRB 1.0". Later in this section, CCWT's next generation of NRBs, or "NRB 2.0" is discussed.

3.2.1. MASSTC Pilot Installations

The Center's research efforts to investigate and optimize the efficiency of nitrogen (N) in NRBs comprised multiple initiatives over the period under review. In addition to analysis of microbial communities, this work included:

- analysis of wastewater from Center sponsored NRBs (NY systems) at the Massachusetts Alternative Septic System Test Center (MASSTC);
- analysis of nitrogen transformations in bench-scale anoxic incubations of denitrifying layer material (woodchip: sand mix);
- analysis of dissolved nitrogen gas in NY-2 and N₂O from all NY systems at MASSTC;
- construction of lab-scale columns to investigate the optimum depth for effective nitrification.

While prior studies have quantified the capacity of in-ground lignocellulose-based bio-filters to remove nitrate from residential wastewater, few have described the nitrogen transformations or microbial communities involved in such processes. Consequently, it is unknown whether nitrate is completely reduced to inert N₂ gas or whether intermediate products such as N₂O gas are produced, nor is it well



understood what quantity of nitrate is absorbed to soils within the system or bio-assimilated by soil microbes. Further, no spatial analysis has been published which documents where within such a system biological N transformation occur. Data addressing these questions are important in optimally sizing engineered systems to effectively nitrify wastewater and denitrify nitrified percolate at the lowest feasible cost.

Center-sponsored NRBs at MASSTC comprising of three different design configurations have achieved significant total nitrogen removal in the final effluent. Spatial analysis of various parameters (nitrogen species, BOD5, alkalinity, DOC & TSS) at different vertical zones within the NRB can reveal chemical processes which regulate nitrogen transformations; e.g., a significant portion of total nitrogen removal occurred in the sand (nitrification) layer particularly in the case of NY-2. This type of spatial analysis allows the Center to focus on specific areas for further research (in-situ monitoring and experiments) to isolate the relevant mechanisms of nitrogen removal.

The goal of one study was to quantify dissolved N_2 gas produced in bench-scale incubations of soil matrix taken from a two-year old, in-ground NRB installed at MASSTC in parallel with q-PCR technique to characterize microbial communities associated with nitrogen transformations. During the six-month period under review, we completed final incubations, analyzed data and wrote the first draft of a manuscript for submission to a scientific journal. The study allowed evaluation of where in the NRB denitrification occurred at a scale of inches, demonstrated how carbon and oxygen levels regulated N_2 production, and described a mass balance between NO_3^- input in wastewater and measured nitrogen transformation products. The study also demonstrated N_2 production can occur in the nitrification layer under anoxic conditions with external carbon additions (e.g., methanol). Such data is critical to understanding total nitrogen loss reported from nitrification layer in the field. The paper is internally under review prior to submission to a relevant journal.

To optimize performance and cost of NY-2 system (sand layer with wood-chip box), the Center investigated dissolved N_2 , NO_3 and NH_4 distributions within its 1,500-gallon wood-chip tank. The samples were taken in September and December 2017 at vertical depths of 17", 27" and 37" inside the box. The results showed dissolved N_2 at excess levels relative to air equilibrium at 27" & 37" and at deficit levels above 17" indicating high N_2 -N production in the bottom 2/3rd of the tank and no N_2 -N production in the upper 17". Both NH_4 and NO_3/NO_2 were below detection at all depths. We hypothesize that the lower dissolved N_2 gas pressure in the upper 1/3rd of the tank is due to warmer temperatures close to the surface compared with those prevailing in the lower tank, but plan to further monitor the system and carry out an experiment (acetylene reduction assay) to confirm. N_2 analysis was measured on the Center's Membrane Inlet Mass Spectrometer; NO_3 and NH_4 were measured on a Lachat Quick Chem Auto-Analyzer™.

All NY systems at MASSTC were analyzed for N_2O flux (a potent greenhouse gases). There are two purposes to the N_2O measurements. N_2O emission have been found in industrial and municipal wastewater treatment plants (WWTPs) where they can be mitigated by altering environmental variables (e.g. O_2 concentrations) in the reactor. There are no published reports on N_2O emissions from NRBs to our knowledge. For this reason, we are analyzing N_2O emissions seasonally to understand if NRBs need to be designed to mitigate N_2O fluxes. Our second purpose is to constrain N mass balances in NRBs to fully understand the fate of TN entering these systems. Preliminary measurements from December 2017 flux chamber samples indicate N_2O emissions to air are less than 1%, a finding comparable or lower than emissions for WWTPs.

Bench-scale columns (6" diameter) of four different heights (3", 6", 12" and 18") will be constructed to test the effectiveness of smaller thicknesses of nitrification layers. This set-up will allow us to collect enough aqueous samples for analysis and to avoid the disruption of the hydraulic flow pattern that sampling mid-column would likely cause. Nitrification matrix will be taken from an in-ground NRB at



MASSTC where microbial colonization of the sand particles developed naturally. All columns will be packed following procedures as like the field systems as possible. Synthetic septic tank effluent will be applied to the surface of the nitrification columns through a one-inch GEOMAT® layer to ensure even distribution. The GEOMAT® is designed to ensure oxygenation of the influent before it reaches the matrix, so we will not deoxygenate the synthetic septic tank effluent. A lab set-up of a 12" nitrification column was constructed during the review period.

3.2.2. Pressurized Shallow Drainfields

Some of the I/A OWTS that take the place of cesspools and septic tanks being installed under Article 19 of the Suffolk County Sanitary Code provide advanced levels of nitrogen reduction by extensive aeration of wastewater to remove organic contaminants measured as BOD₅ and oxidize ammonium to nitrite and nitrate. These units have been adopted to treat septic tank effluent (STE) before the water enters the pressurized shallow drainfields (PSD). The extent of nitrogen removal in the PSDs largely depends on native soil properties and the hydraulic loading of the system, since the denitrification process is carried out by heterotrophic bacteria in anoxic environment. However, the efficacy of PSDs dosed with advanced treatment effluent (ATE) in removing nitrogen in final effluent has been evaluated only to a limited extent. Although it has been positively predicted that an additional 30-50% of nitrogen removal could be achieved by the PSD, there is a lack of experimental data to support this hypothesis. The Center's research efforts to monitor and evaluate the efficiency of nitrogen removal in PSDs comprised multiple initiatives over the period under review. This work included (1) Identify the PSD locations for seasonal monitoring and install the suction lysimeters to various depths of the PSD. (2) Conduct seasonal analysis of wastewater collected from the lysimeters and evaluate the additional nitrogen removal by the PSD after the I/A OWTS treatment. CCWT has collaborated from the County for selection of test sites.

Two sites were identified and were monitored monthly since December 2017. At each drainfield site, the soil treatment area receives dosing effluent from the proprietary I/A OWTS installed under Article 19. The infiltrative surface is 15-30 cm below the ground surface. A total of 12 vacuum lysimeters are located at three different depths of 6, 12 and 24 inches to collect 24-hour replicate composite intermediate and effluent samples.

Table 23 shows the preliminary data obtained from the PSD in the two systems in December 2017. We also compared the results obtained from the effluent of the proprietary unit (data from Suffolk county). Monitoring of these systems provides more information regarding the efficiency and possibility of further nitrogen removal in soil matrix of the PSDs. Since these systems have been installed recently and the data obtained are only preliminary, no conclusions regarding their efficiency could be stated at this stage.

Table 23 - Preliminary Data - Pressurized Shallow Drainfields

4 Sheppard Lane, Stony Brook (unit: mg/ L)			
Total nitrogen in system effluent ⁽¹⁾		9.4	
Depth	NH ₄ ⁺	NO ₃ ⁻	Dissolved Inorganic Nitrogen
6"	2.27	4.63	6.90
24"	0.04	3.01	3.06
2 Sandys Lane, Remsenburg (unit: mg/ L)			
Total nitrogen in system effluent ⁽¹⁾		53.1	
Depth	NH ₄ ⁺	NO ₃ ⁻	Dissolved Inorganic Nitrogen
12"	9.41	3.07	12.48
24"	0.02	7.91	7.92
⁽¹⁾ TN measurements from proprietary system supplied by Suffolk County			



3.2.3. Full-Scale Experimental Installations in Suffolk County – Installed Systems

CCWT retained an engineering consultant licensed to practice professional engineering in New York State to design and prepare construction documents for the installation of nine (9) NRB 1.0 residential systems as shown in Table 24 and 25.

Table 24 - Installed NRB Systems

NRB Ref.	Flow (GPD)	Project Location (Project Identifier)	System Type *	Septic Tank (Gals.)	Pump Station Size (Gals.)	Nitrification Sand Bed (S.F.)	Bed Loading Rate (GPD/S.F.)	Denitrification Box Size
1 ⁽¹⁾	550	9 Private Rd., Shirley, NY	Lined #1 (Saturated)	1,500	1,000	733	0.75	NA
2 ⁽¹⁾	440	59 River Rd., Shirley, N.Y.	Unlined #1 (Unsaturated)	1,000	1,000	880	0.50	NA
3 ⁽¹⁾	550	221 Old River Rd., Calverton, N.Y.	Box #1 (Saturated)	1,500	1,000	733	0.75	2,000
7 ⁽²⁾	440	Uplands Farms No. 1 (The Nature Conservancy)	Unlined #2 (Unsaturated)	1,000	1,000	587	0.75	NA
8 ⁽²⁾	440	Uplands Farms No. 2 (The Nature Conservancy)	Unlined #3 (Unsaturated)	1,000	1,000	587	0.75	NA

* CCWT Short Name Abbreviation for Type of System

(1) NRB constructed and placed on-line in April / May 2018

(2) NRB constructed and placed on-line in December 2018

As of the writing of this technology review, 5 projects were constructed in 2018 as shown in Table 24. The contract prices for the 5 installed systems are as follows:

- NRB System 1 (9 Private Drive): \$57,500
- NRB System 2 (59 River Road): \$65,800
- NRB System 3 (291 Old River Road): \$75,000
- NRB System 7 (TNC Upland Farms - Cottages #1 and #3): \$38,862
- NRB System 8 (TNC Upland Farms – Cottage #2): \$38,862

All systems treat wastewater from residential homes.

As of the writing of this document, systems 1 and 2 are treating domestic wastewater and performance data have started to be collected by SCDHS and CCWT. The home for system 3 is currently unoccupied, so wastewater is not being generated. Systems 7 and 8 were just placed on-line in December 2018.



These photos provide an overview of the construction of the three variations of the NRB system.



59 River Road (Unlined System)



9 Private Road (Lined System)



221 Old River Rd. - (Box System)

CCWT has also undertaken a sampling and analysis program to supplement the Article 19 laboratory analysis being conducted by SCDHS. CCWT is undertaking this supplemental program voluntarily to test for additional analytes, such as phosphorus, personal care products, pharmaceuticals, and metals. Samples for these analytes will be taken quarterly. CCWT will also be collecting grab samples and laboratory testing for those parameters specified in Article 19, whereas SCDHS collects 24-hour composite samples. CCWT will then be able to compare the results of the grab samples with those of the 24-hour composite samples. The results should help to understand the benefits of composite sampling vs. grab samples, if any. This analysis will prove useful to perhaps reduce the effort necessary to confirm compliance with Article 19.

Two pilot nitrogen-removing biofilters (NRBs) installed in Suffolk County, NY (Unlined #1 and Lined #1) were monitored from May-December 2018. Septic tanks and NRB effluent were sampled on a monthly basis while pump tanks and interface lysimeters were sampled on a quarterly basis. Since effluent is not collected in the unlined system, samples collected from lower lysimeters located at the bottom of the NRB were treated as an effluent analog. These samples were analyzed for nitrate + nitrite (NO_x), ammonia (NH₄⁺), total Kjeldahl nitrogen (TKN), 5-day biochemical oxygen demand (BOD₅), and



alkalinity. Total nitrogen (TN) was obtained by addition of TKN and NO_x. Effluent samples were additionally analyzed quarterly for total coliforms, fecal coliforms, and E. coli.

Figures 3 and 4 show the results of CCWT's sampling program for the unlined and lined NRBs.

Figure 3 - Performance Results for Unlined NRB

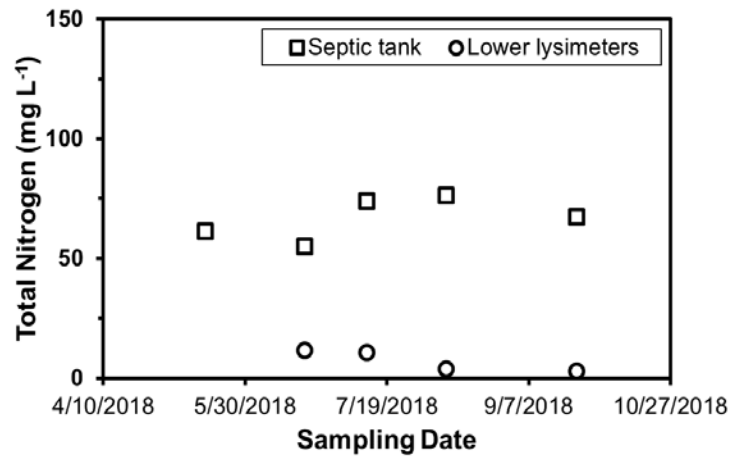
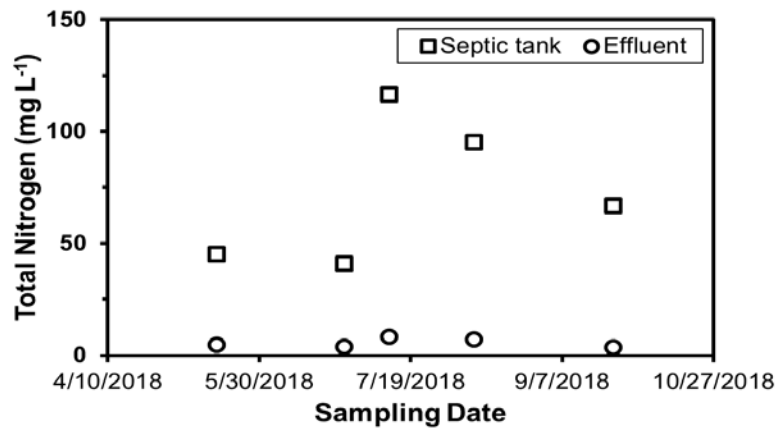

Figure 4 - Performance Results for Lined NRB



As shown, both systems are producing less than 10 mg/L of total nitrogen.

3.2.4. Full-Scale Experimental Installations in Suffolk County – Not Yet Installed

In addition to the installed NRB projects, CCWT has authorized the re-design of 3 additional NRB 1.0 systems for residential homes. These systems are being redesigned to reduce costs after bids were requested and received. Construction for system #6 should be completed in 2019 as soon as the weather allows. The following table provides relevant information for the systems that are not yet installed:



Table 25 - Summary of NRB Systems Not Yet Installed

NRB Ref.	Flow (GPD)	Project Location (Project Identifier)	System Type *	Status
4	220	67 Middle Island Road	Boxed #2	Under Re-Design
5	220	71 Yaphank Middle Island Road	Lined #2	Under Re-Design
6	550	264/300 Old River Road, Shirley, NY	Lined #3	P.O. Issued to Contractor
9	550	10 High Hold Drive Huntington, NY	Box #3	Under Re-Design

* CCWT Short Name Abbreviation for Type of System

CCWT is projecting that the NRB residential systems shown in Table 25 will be fully operational by the end of the first quarter of 2019, budget permitting. ¹ CCWT currently do not have plans to install additional NRB 1.0 residential systems at this time. However, CCWT is in discussion with several Suffolk County municipalities to install NRB systems for commercial type installations, as defined by SCDHS. We are now working with the Towns of Southampton and East Hampton to install NRBS.

3.3. Next Generation Nitrogen Removing Biofilters (NRB 2.0)

CCWT has started the development of the next generation of nitrogen removing biofilters, (a.k.a. NRB 2.0). This section of the annual report provides NYSDEC with relevant information concerning the design enhancements brought about through study and application of practical and proven methods of wastewater treatment found in centralized municipal wastewater treatment. Focused attention for reducing the cost of installation is a priority for NRB 2.0.

The basis for significant cost reduction rests on three essential design objectives, namely:

1. Reducing the footprint dimensions of the nitrification sand filter unit process;
2. Reducing the detention time of the denitrification wood chip bioreactor unit process and/or improve overall efficiency of denitrification process;
3. Reducing the extent of controls, valves, and associated hardware.

The following provides the methodology/description employed by CCWT for accomplishing these main objectives.

3.3.1. Design Charrette

On February 15, 2018 the Center hosted a design charrette to bring together leading experts on NRBS to identify opportunities to reduce the cost of NRB systems, from design through construction, and to determine new opportunities for lignocellulose and sulfur-based onsite wastewater treatment systems. Achieving both goals could effectively position NRBS and similar layered soil treatment systems as a high performance and economically viable solution for reducing nitrogen and other contaminants from household wastewater in Suffolk County and in an emerging national and global market.

The charrette resulted in 4 concepts to reduce installation costs as shown on the following figure:

¹ In accordance with SCDHS Article 19 requirements, experimental systems data will be collected for one year. If the results comply with the requirements of Article 19, then the installed systems will be promoted to the provisional phase of SCDHS approval. By the end of 2019, CCWT is confident that 5 of the 9 systems will have gained promotion to the provisional phase.

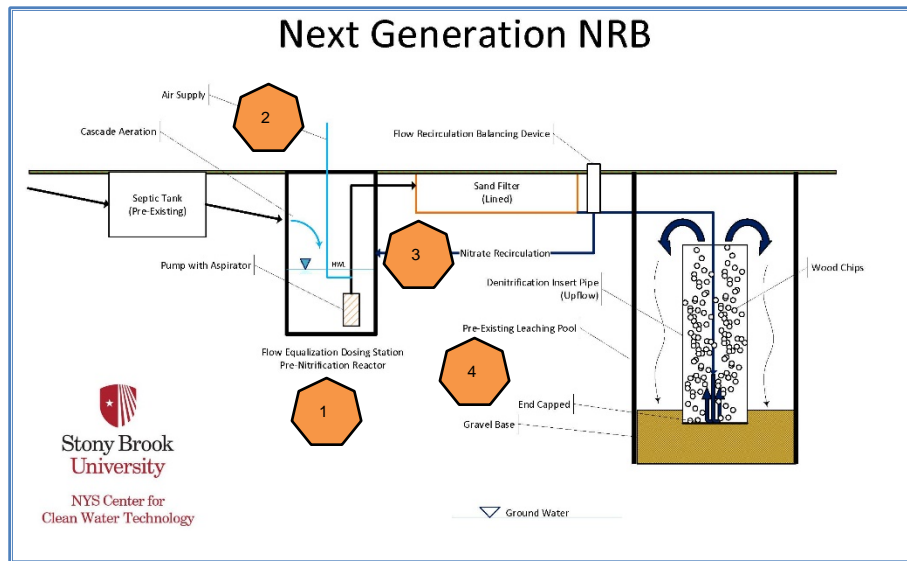

Note: Concepts are depicted by heptagons

Figure 5 - Design Charrette Concepts

The four concepts are as follows:

Concept 1: The pump station used for NRB 1.0 accepts wastewater from the septic tank for conveyance to the nitrification sand filter. The concept is to provide flow equalization at the pump station such that the sand filter treats a constant flow over a 24-hour period instead of an intermittent dosed flow, as is the NRB 1.0 design feature. The reasoning is that the bacterial population within the sand filter has a constant food source, which is a common design practice in biological nutrient reduction processes employed at municipal wastewater treatment plants. A constant flow may result in a higher hydraulic loading rate, which translates to a smaller sand filter footprint and/or a sand filter layer of less than 18-inches, which is the requirement for NRB 1.0. This would reduce the cost of constructing the nitrification sand filter.

Concept 2: Atmospheric oxygen is introduced at the pump station, thus "conditioning" the septic tank effluent to an oxygen enriched wastewater. The working theory is that carbonaceous BOD reduction and ammonification processes are "jump started" prior to the nitrification sand filter, thus allowing an increase in hydraulic loading rate and/or a sand layer less than 18-inches. This would reduce the cost of constructing the nitrification sand filter.

Concept 3: The average daily flow from the sand filter is gravity conveyed to the denitrification wood chip step under NRB 2.0. The concept is to recycle a portion of the flow back to the pump station effectively treating the wastewater multiple times. The working theory is that recycling wastewater would result in a hydraulic loading rate greater than that of NRB 1.0. This would reduce the cost of constructing the nitrification sand filter.

Concept 4: For installations where the existing leaching pools are reusable, then provide for the denitrification wood chips to be "inserted" within the leaching pool. This repurposing of the leaching pools serves to reduce the need for a separate installation of a bioreactor following the sand filter. The sand filter effluent is gravity conveyed to the bottom of the denitrification insert, thus providing an upflow wood chip bioreactor where the denitrified effluent then overflows into the leaching pool for final discharge to groundwater. This concept is workable only if the groundwater level is at least 2 feet below

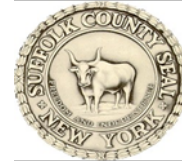

the bottom of the leaching pool. The repurposing of the leaching pool eliminates the need for a separate wood chip precast structure and would substantially reduce the overall cost of the system.

3.3.2. Post Charrette Brainstorming

CCWT analyzed the results of the charrette and conducted an in-house brainstorming session to further expand on the enhancement concepts. Discussions led the CCWT team to incorporate the nitrate recycling concept employed in the Modified Ludzack-Ettinger (MLE) process. The MLE process is one of the most commonly used biological nutrient removal processes used in municipal activated sludge treatment schemes. The MLE process uses an internal recycle rate of 2 to 4 times the average daily flow where the effluent from the aerobic step is recycled back to an anoxic reactor located ahead of the aeration tank. The anoxic reactor has sufficient BOD (carbon food source) from the incoming flow to convert nitrates to nitrogen gas. CCWT reasoned that instead of an anoxic activated sludge system, an intermediate wood chip reactor could be used.

3.3.3. NRB 2.0 Design

Figure 6 is a simplified process schematic for NRB 2.0 that resulted from the post-charrette brainstorming session. The schematic introduces the concept of an intermediate wood chip bioreactor which constantly converts nitrate to nitrogen gas. (The schematic also shows a polishing wood chip biofilter inserted within an existing leaching pool.)

The flow from the home is gravity conveyed to a septic tank sized in accordance with SCDHS standards. The septic tank effluent then flows by gravity to a pump station that equalizes the diurnal flow fluctuations over a 24-hour period and provides organic load buffering, thus eliminating organic shock loads, like the use of a flow equalization basin used in municipal wastewater treatment plants. Atmospheric oxygen is also introduced to the pump station wet well as explained above and serves to mix the contents of the basin to effect organic load buffering. As shown, the recycle flow that has been partially denitrified via the intermediate biofilter is returned to the pump station. Therefore, total flow to the sand filter is equal to the average daily flow plus the recycle flow; this is termed Q_T . The wet well of the pump station is sized to equalize the flow such that the forward flow to the sand filter is equal to $5Q$ (5 times the average daily flow) over a 24-hour period.²

The total flow of $5Q$ is pumped to a pressurized shallow drainfield that distributes the flow evenly across the footprint of the sand filter bed, consisting of C33 ASTM classified sand.³ The percolate is captured

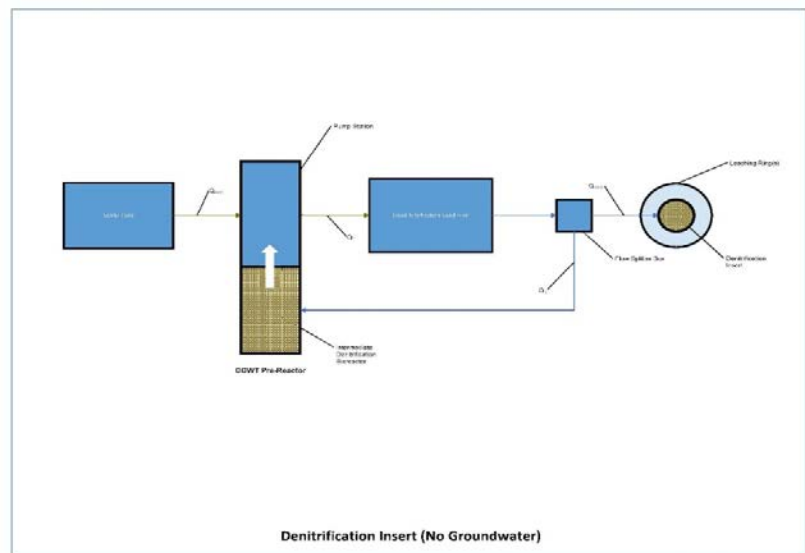

Figure 6 - NRB 2.0 Intermediate Bioreactor Process Schematic

² Like the MLE process, the recycle flow rate would initially be tested at 4 times the average daily flow. For example, a 5-bedroom home with an average daily flow of 550 GPD, the recycle rate is 2,200 GPD (4 x 550 GPD) or approximately 1.5 gallons per minute (GPM) over a 24-hour period. the pump station is sized to equalize the $5Q$ flow.

³ Other types of sands will be tested at CCWT's Research Facility.



through an underdrain system, which then flows by gravity to a flow splitter box. The flow splitter box serves to proportion the forward flow to the final denitrification wood chip biofilter at 1Q, while the recycle flow of 4Q returns through the intermediate biofilter to the influent flow equalization pump station.⁴

Sand Filter: NRB 1.0 uses a surface loading rate for the sand filter of approximately 0.75 GPD / Sq. Ft. Our working theory is that the sand filter surface loading rate can be increased to at least 3.0 GPD / Sq. Ft. for NRB 2.0. This is best illustrated for a design flow assuming 550 GPD. The sand filter footprint dimension for the NRB 1.0 system is 733 Sq. Ft. (550 GPD / 0.75 GPD per Sq. Ft. = 733 Sq. Ft.). The sand filter footprint dimension for the NRB 2.0 system is 183 Sq. Ft. This results in a surface area of approximately 4 times smaller than NRB 1.0.

NRB 1.0 Biofilter: NRB 1.0 uses a total hydraulic retention time of approximately 72-hours (4,320 Min.). Therefore, assuming the 550 GPD (0.051 Cu. Ft. per Min.) flow, the NRB 1.0 required volume of the single biofilter is approximately 220 Cu. Ft. (0.51 Cu. Ft. per Min. x 4,320 Min.). Adjusting for a porosity of the wood chips of 40% results in an effective volume of 308 Cu. Ft.

NRB 2.0 Final Polishing Biofilter: Our working theory is that the final polishing biofilter detention time can be reduced to approximately 24-hours (1,440 Min.) with the detention time for the intermediate biofilter set at approximately 16-hours (960 Min.).⁵ Therefore, assuming the 550 GPD (0.051 Cu. Ft. per Min.) flow, the NRB 2.0 required volume for the final polishing biofilter is approximately 73 Cu. Ft. (0.51 Cu. Ft. per Min. x 1,440 Min.). Adjusting for a porosity of the wood chips of 40% results in an effective volume of 102 Cu. Ft.

NRB 2.0 Intermediate Biofilter: The intermediate biofilter treats 4Q or 2,200 GPD (0.204 Cu. Ft. per Min.); therefore, the required volume is approximately 196 Cu. Ft. at a hydraulic retention time of 16-hours (0.204 x 960 Min.). Adjusting for a porosity of the wood chips of 40% results in an effective volume of approximately 274 Cu. Ft.

The total effective volume for both NRB 2.0 biofilters is approximately 376 Cu. Ft. (102 Cu. Ft. + 274 Cu. Ft.). Therefore, the NRB 2.0 system requires approximately 68 Cu. Ft. (376 Cu. Ft. - 308 Cu. Ft.) additional volume of wood chips or 22% more.

3.3.4. Pilot Testing of NRB 2.0

The assumptions made for detention time, surface loading rate, and recycle rate will be tested via experiments at CCWT's Research Facility. The objectives of the tests are to determine the optimum design values and the efficiency of the nitrification/denitrification process by the addition of an intermediate biofilter.

3.4. CCWT Wastewater Research and Innovation Facility (WRIF) (a.k.a. Research Facility)

Figure 7 on the next page shows a site plan of CCWT's Research Facility.

The project is broken down into 5 phases. Phase 1 was the direct purchase of the trailers that comprise the facility. Phase 2 was the pre-purchase of equipment by CCWT for installation under Phase 3. Phase 4 is the startup of the system and loading of the various experimental columns with sand, gravel, wood chips and biochar.

⁴ The initial recycle flow established for piloting testing will be 4 times the average daily flow. CCWT will run experiments at CCWT's Research Facility to determine the optimum recycle rate.

⁵ CCWT will determine the optimum detention time of the intermediate biofilter and final polishing biofilter via experiments conducted at CCWT's Research Facility.



Phase 5 is the implementation of the various experiments and full operation of the facility. As of the writing of this document, CCWT's Research Facility is in Phase 4 of the project.

A public bid was received in early 2018 for Phase 3 which included plumbing and site work associated with the construction of CCWT's Research Facility. The lowest, responsible and qualified bid of \$158,800 was accepted and a construction contract was awarded.

In addition to experimenting on NRB 2.0 as described above, the Research Facility will be used to conduct column and bench testing as depicted on the figure included in Appendix A.

CCWT was also successful in being granted additional land by Suffolk County for expansion of the research capabilities to include full-scale pilots for NRB 2.0 and wetlands treatment systems. Figure 7 also shows the expansion area relative to the research trailers.



Figure 7 - Research Facility with Expansion Area

As of the writing of this document, the clearing and grubbing of the site has been completed and a perimeter fence has been installed. The designs for the full-scale pilot installations are being finalized and additional equipment needs are being assessed. CCWT will continue to keep NYSDEC informed on the status of the research that will be conducted at the Research Facility in upcoming quarterly reports.

The following photos provide a glimpse of the Wastewater Research and Innovation Facility. It should be noted that representatives from NYSDEC Region 1 have toured the facility and we welcome other NYSDEC representatives to visit the facility



This facility is unique because it is the only research facility in New York State dedicated to the development of onsite wastewater treatment systems. In fact, CCWT has received numerous requests from private industry I/A OWTS process system developers to study and pilot their systems, with the expectation that if proven successful to obtain Article 19 nitrogen limits, they will be allowed to participate in the County's Septic Improvement Program. We have made substantial progress in bringing this facility on-line in 2018 and have done so with the help of volunteers devoted to its successful operation.



Main Trailer with Column Experiments



Trailer with Bench-Top Experiments



Staff Installing Media into Sand Filters



Close-up of Experiment Columns



Staff Washing Gravel for Sand Filter Columns



Overall View Inside Column Trailer



4. I/A OWTS TECHNOLOGIES IN USE IN PROXIMAL JURISDICTIONS

Prior to developing an I/A OWTS management program, Suffolk County embarked on a tour of 4 north eastern states to evaluate their programs. This tour included: New Jersey, Maryland, Rhode Island, and Massachusetts. Lessons learned from these jurisdictions were instrumental in assisting the County in the development of a robust I/A OWTS management program and as such, the County has continued to consult with contacts in these jurisdictions throughout the Suffolk County Demonstration Program.

The following tables show the I/A OWTS approved for use in these jurisdictions along with performance data through 2017.

Table 26 - I/A OWTS Approved in Proximate Jurisdictions

Technology	Jurisdiction				
	Suffolk	MA	RI	MD	NJ
Advantex AX Series	•	•	•	•	
Advantex AX-RT Series	•	•	•	•	
Amphidrome	•	•	•		•
AquaKlear				•	
BioBarrier MBR	•	•	•		•
Bioclere		•	•		•
Busse	•				•
Ecoflo Coco	•			•	
FAST		•	•		•
Fuji Clean	•			•	
Hoot ANR					•
Hoot BNR				•	
Hydro-Action AN Series	•			•	
Hydro-Kinetic	•		•	•	
MicroFAST		•		•	
Mod FAST		•			
Nitrex		•	•	•	
Nitrex Plus		•			
OMNI Recirculating Sand Filter		•			
OMNI-Cycle System		•			
Recirculating Sand Filter	•	•	•		
RetroFAST				•	
RID Phosphorus Removal System		•			
RUCK		•			
RUCK CFT		•			
SeptiTech		•	•	•	•



Singulair DN	•	•		
Singulair TNT	•	•	•	•
Waterloo Biofilter	•			
White Knight			•	

• General Use
• Provisional Use/Undergoing Field Verification
• Piloting Use

Table 27 - 2016 Comparison of I/A OWTS Results

Technology	NSF 245 or ETV Certification	Suffolk County	Maryland	Barnstable County	New Jersey Pinelands
Advantex AX	NSF 24 mg/l	24.2 mg/L	17.0 mg/l	17.9mg/l	
Advantex RT		18.8 mg/L	14.52 mg/l		
HydroAction	NSF 15 mg/L	11.6 mg/L	20.33 mg/l		
Norweco Singulair	NSF 12 mg/L	18.3 mg/L	27.0 mg/l	23.5 mg/l	
Norweco Hydro-Kinetic	NSF 7.9 mg/L	17.5 mg/L			
BUSSE MF	NSF 16 mg/l	83.4 mg/L			
Amphidrome	ETV 10.81 mg/L	17.7 mg/L			12.5 mg/l
BioMicrobics BioBarrier	NSF 9 mg/L	49.7 mg/L			24.3 mg/l
BioMicrobics FAST	NSF 17 mg/L		25.44 mg/l	20.4 mg/l	18.1 mg/l
BioMicrobics SeptiTech	NSF 17 mg/L		20.0 mg/l	12.6 mg/l	17.9 mg/l
Bioclere				21.5 mg/l	12 mg/l
OMNI Recirculating Sand Filter				19.7 mg/l	
Ruck				20.35 mg/l	
AquaKlear			27.47 mg/l		
Hoot BNR			21.0 mg/l		
FujiClean	NSF 10 mg/L	16.6 mg/L			
Pugo	NSF 17 mg/L	28.6 mg/L			
Ecoflow Coco	NSF 18.6 mg/L	37.4 mg/L			
Ecoflow Coco + Denite		29.8 mg/L			
Waterloo BioFilter	ETV 14 mg/L	54.3 mg/L		17.7 mg/L	



5. I/A OWTS TECHNOLOGIES IN THE GLOBAL MARKET

CCWT held a press event on April 26, 2018 at 9 Private Drive in Shirley to bring attention to the research work being undertaken by CCWT. The event also provided public outreach to various stakeholders. Ms. Karen Gomez, P.E. from NYSDEC Region 1 was in attendance and provided remarks regarding the importance of the program.

The event was attended by elected officials, Suffolk County, environmental advocacy groups, researchers, and others who would have a vested interest in the development of a non-proprietary I/A OWTS, such as contractors/installers and material and equipment suppliers. While the event was organized as a first-step for public outreach, it also created a dialogue with companies who one day would be engaged in the construction of NRB systems across Suffolk County. Business opportunities between CCWT and potential startup companies dedicated to expanding the business of I/A NRB systems were discussed. There appeared to be great interest and CCWT will look to expand our public outreach towards the objective of creating a local, regional, national and then global market for a non-proprietary nitrogen removing on-site wastewater treatment systems.

CCWT has prepared several white papers on the subject and have presented at trade type conferences that serve to “get the word out” that CCWT is developing a system that will one day replace cesspools and septic systems. CCWT believes that this is the first step towards marketing the advancements of CCWT towards the overarching goal of creating a global market for the system.

While the goal of establishing a global market is important, our main focus has been to gain SCDHS Article 19 approval for “general use”. Once the NRB experimental systems are all installed (as discussed in Section 3 of this document), and CCWT is able to generate performance data that proves worthy of the general use designation, then additional public outreach events and installation training courses can be undertaken to further advance the global market initiative.



No text this page



6. **PUBLIC OUTREACH**

This section describes our efforts to provide public outreach.

6.1. CCWT

The Center's website (www.stonybrook.edu/cleanwater) continues to expand as efforts of the Center progress and will continue to serve as a primary outreach tool. In preparation for several performance measures included in the current work plan, the Center has expanded this web site to include a new "Research" tab which will allow us to provide quarterly updates on each research track.

Members of the Center are actively engaged as both speakers and participants at several meetings and conferences to stay up to date on current research and trends regarding clean water technology. Recent activities include:

- On October 2, 2017 several representatives from the Center attended the Water Environment Federation Technical Exhibition and Conference in Chicago, IL to present on Nitrogen Transformations and Microbial Characterization in Passive Nitrogen Removing Bio-Filters for Onsite Wastewater Treatment.
- On October 13, 2018 Center Co-Director, Dr. Hal Walker attended the Long Island Water Conference.
- On October 24, 2017 Center Co-Director, Dr. Chris Gobler, attended a NYS Forum & Round Table Discussion held by Citizens Campaign for the Environment entitled Recognizing Our Clean Water Challenges, and Creating a Shared Vision for Solutions where he presented on harmful algal blooms.
- On October 27, 2018 the Center hosted Dr. Kartik Chandran, Professor and Director of CUBES Program at Columbia University, for a presentation on Carbon Based Interactions in Autotrophic N-Cycle Communities.
- November 3, 2017 - Co-Director Christopher Gobler gave the presentation highlight the work of CCWT called: "How safe is Long Island's drinking water, and what Stony Brook University is doing to help" to the group, Science Advocacy for Long Island inaugural meeting.
- On November 8, 2017 graduate students Molly Graffam and Samantha Roberts attended the Coastal & Estuarine Research Federation's 2017 Conference in Providence, RI.
- On November 13, 2018 Center Co-Director, Dr. Hal Walker, attended a meeting of the NY League of Conservation Voters to receive an award on behalf of the Center.
- December 7, 2017- Co-Director Christopher Gobler gave the presentation highlight the work of CCWT called: "Harmful algal blooms: A growing threat to NY's drinking and surface water", to the New York Water Environmental Association via webinar.
- On February 5-7, 2018 graduate students Sarah Lotfikatouli and Zahra Maleki Shahraki attended the NYWEA Annual Meeting in New York City; in addition, graduate student Samantha Roberts gave an oral presentation at this meeting on the role of plants and the rhizosphere in mediating nitrogen transformations in constructed wetlands for wastewater remediation.
- On February 15, 2018 Co-Director, Dr. Hal Walker, attended Senator LaValle's Environmental Roundtable to provide an update on Center activities.
- On May 22, 2018 the Center hosted a symposium. It was attended by over 100 professionals engaged in the protection of our water resources.



- On October 24, 2018 Mr. Frank M. Russo, P.E. presented at the Long Island Chapter of the Clean Water Partnership Conference. He provided a concise update of the NRB process. Graduate students Ms. Molly Graffam and Ms. Samantha Roberts also presented on Wetlands Treatment Systems and Permeable Reactive barriers.
- On October 25, 2018 Mr. Russo also presented a 1 hour talk on NRBs to the Long island Chapter of the New York water Environment Association.

6.2. Suffolk County - Industry Training & Education

Industry training is the single most important thing when starting a new program. Systems installed and maintained without trained operators can lead to malfunction and failure and tarnish an otherwise proven technology. One of the very first actions the County took was to revise the liquid waste law in 2015, became effective in June of 2016. Liquid Waste License is managed by the licensing section of Suffolk County Consumer Affairs Department. Previously anyone with a liquid waste license could do any work without any training. (i.e a master plumber could rent an excavator and install a septic system without any training). The law created 11 new endorsements on the Liquid Waste License and training requirements for each endorsement. In addition, continuing education requirements are now required upon every 2-year license renewal. The following training classes were offered in 2017:

- OWT105: Innovative and Alternative System Overview Class
 - 4/19/17: 30 PARTICIPANTS
 - 4/21/17: 30 PARTICIPANTS
 - 6/20/17: 47 PARTICIPANTS
 - 12/20/17: 30 PARTICIPANTS
- INST100: Conventional System Installation Overview Class
 - 4/20/17: 53 PARTICIPANTS
 - 6/21/17: 17 PARTICIPANTS

6.3. Suffolk County - Public Outreach

- Updated Suffolk County Sanitary Code for Cesspool Phase-out and held related workgroup and stakeholder meetings on 1-6-17, 1-26-17, 2-15-17, 3-15-17, 3-31-17, 4-27-17, 5-5-17, 5-25-17, 9-7-17.
- Completed Suffolk County Septic Improvement Program (SIP) Town Hall Meetings on 4-24-17 in Flanders, 4-27-17 in Port Jefferson, 5-8-17 in Huntington, and 5-12-17 in Centereach.
- Presented Suffolk County Septic Improvement Program (SIP) at Miramar Beach Civic Associations on 5-23-17, East Moriches Property Owners Moriches Bay Civic Association 5-31-17, Patchogue Rotary Club 6-7-2017, Mastic Beach Civic Meeting 8-2-17, Bellport Village Civic Meeting 7-26-2017, and Commack Civic Group 9-20-2017.
- Participated in Suffolk County Septic Improvement Program (SIP) briefing calls with various civic groups on 3-28-17 and Town Supervisors on 6-12-17.
- Held Suffolk County Septic Improvement Program (SIP) public stakeholders meetings on 7-12-17 in Selden and 7-13-17 in Riverhead.



In addition to the items listed above, the County developed an informative, easy to use website at www.ReclaimOurWater.info. The website provides the public with the most up to date information on I/A OWTS and the County's Septic Improvement grant and loan program.

6.4. 2017 Suffolk County Septic Improvement Program Summary

The Suffolk County Septic Improvement Program (SIP) launched on July 3, 2017 at www.ReclaimOurWater.info. The Program provides homeowners looking to install new nitrogen reducing septic systems (known as I/A OWTS) with grants up to \$11,000 to offset the increased costs of these new technologies. In addition, homeowners may apply to participate in a loan program administered by a third-party lender to finance the remaining cost of the system. The County has enough funding to issue approximately 185 – 200 grants per year. Applications are accepted on a rolling basis and priority is given to high and medium density residential parcels located within the 0 to 25-year groundwater travel time or within 1,000 feet of enclosed waterbodies. Post-installation landscaping and irrigation restoration is the responsibility of the property owner.

- Program Statistics as of December 26, 2017:
 - No. of Registrants: 852
 - No. of Completed Applications: 231
 - No. of Active Grant Certificates: 165
 - No. of Installations: 8
- List of Installations:
 - Flanders Road, Flanders, NY 11901 - HydroAction AN Series
 - Bayview Road, Remsenburg, NY 11960 – Norweco Singulair TNT
 - Noyack Road, Sag Harbor, NY 11963 - HydroAction AN Series
 - Harbor View Drive, East Hampton, NY 11937 - HydroAction AN Series
 - Westview Drive, Mattituck, NY 11952 - HydroAction AN Series
 - Woodspath Lane, East Moriches, NY 11940 - Norweco Singulair TNT
 - Jennings Avenue, Patchogue, NY 11772 - HydroAction AN Series
 - Seven Ponds Town Road, Water Mill, NY 11976 - Norweco Singulair TNT



No text this page



7. EMERGING TECHNOLOGIES AND CCWT FUTURE RESEARCH NEEDS

This Section provides an overview of the detailed information presented in CCWT's quarterly report to NYSDEC for the period of September 1, 2017 – February 28, 2018. In addition to NRBs CCWT is investigating and researching the use of constructed wetlands treatment systems, biochar, and Membrane Bioreactor (MBR) and ANNAMOX treatment system in the development of onsite wastewater treatment systems.

7.1. Constructed Wetlands

MASSTC: Frequent regular (bi-monthly) sampling of the wetland mesocosms were conducted at the MASSTC during October, December and February. These recirculating wetlands were installed in Spring 2017 and were constructed as a series of replicates to test the effect of planting density (number of plants per unit) on the nitrogen removal processes occurring within wetlands. These wetlands were designed as unsaturated units with the primary intent of providing adequate nitrification of septic tank effluent. Aqueous samples were taken from various sampling ports and are analyzed for nitrogen species concentrations.

Figure 8 represents typical nitrogen speciation within the wetland mesocosms over time. In October and December, the wetlands are performing as anticipated, with nitrate (the product of nitrification) as the dominant nitrogen species in the aqueous samples.

In February, however, there is a shift in the nitrogen speciation, with ammonium concentrations constituting approximately half of the N-species. Further information can be inferred from examining in-situ data, which shows lower than anticipated O_2 concentrations (~ 3.0 mg/L). As plants have senesced in these later winter months it is possible that this litter material is driving consumption of O_2 which can potentially compete with the nitrification process. These observations can inform modifications to operational considerations to further promote aeration of the effluent. These systems will be carefully monitored over time to see whether nitrification efficiency continues to change during spring and summer.

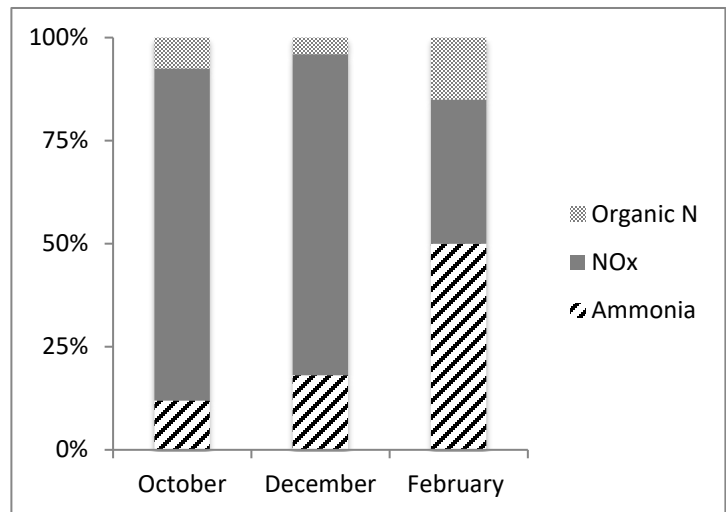

Figure 8 - Nitrogen Speciation

One of the primary hypotheses of this work is that plants and planting density exert a strong control on the processes related to nitrogen transformations. In particular, wetland plants can control nitrification and denitrification by providing oxygen and carbon-rich compounds in the root zone, creating microsites where these processes can happen in proximity. We hypothesize that there will be an ideal planting density that corresponds to optimal nitrogen removal efficiencies. Any planting density below this will result in sub-optimal nitrogen removal and will be NO_x limited due to reduced oxygen supply. At higher planting densities we hypothesize that the process of plant uptake would compete for NO_x with nitrification and denitrification. Preliminary data broadly supports this hypothesis, demonstrating reduced nitrogen removal efficiencies at the lowest and highest planting densities and higher nitrogen removal at intermediate planting densities.

In summary, the wetland mesocosms are performing the primary function they were intended for, to nitrify the ammonia from the influent wastewater into nitrate. Additionally, these wetlands are exceeding our expectations by providing $\sim 50\%$ total nitrogen reduction from the influent wastewater.

Preliminary analysis of total carbon in the influent wastewater suggests that these wetlands are carbon-limited ($C:N < 2$). Studies have documented the effect of influent C:N on total nitrogen removal and have demonstrated



increased total nitrogen removal efficiencies at higher C:N ratios (C:N between 4-10). To improve nitrogen removal for these systems, all treated effluent from the wetlands are subsequently routed into one of two carbon-rich media barrels where under prevailing saturated conditions denitrification can occur to permanently remove nitrogen through the conversion of nitrate to N₂.

The data in Figure 9 demonstrates marked total nitrogen reductions to ~90% even in colder winter months. Total nitrogen removal in February was limited because the dominant form of nitrogen was ammonia, which cannot be denitrified. Any nitrate that was provided to the columns was effectively denitrified with NO_x concentrations <2.5 mg N/L in February.

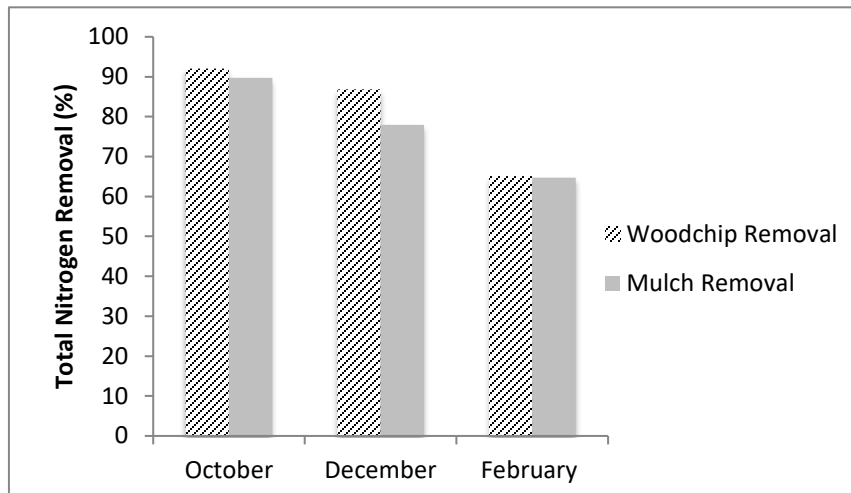

Figure 9 - Marked Total Nitrogen Reductions

Sylvester Manor: The Center has continued to monitor the recirculating gravel filter in operation since July 2017 at Sylvester Manor Educational Farm on Shelter Island.

Figure 10 presents preliminary results from the first sampling season of operation at Sylvester Manor. With each successive month system performance with respect to total nitrogen removal improved, reaching well below the target 19.0 mg/L. In addition to monitoring the outflow concentrations, the Center also installed two intermediate sampling ports within the constructed wetland to better monitor what is occurring within the system.

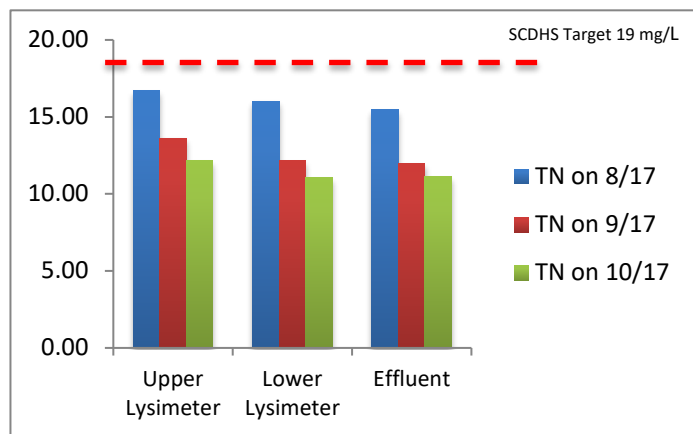

Figure 10 - Sylvester Manor Gravel Filter

As anticipated, the sampling port at deeper depths shows lower total nitrogen, indicating that there is significant removal of nitrogen with depth in the wetland. Within all ports the primary species of nitrogen is nitrate, suggesting nitrification is a dominant process. Using typical influent nitrogen concentrations of 50 mg/L, this system provides ~76% nitrogen reduction. The Center is currently coordinating with Sylvester Manor Educational Farm to develop a sampling scheme for the 2018 operational season.



Georgica Pond: The Center has submitted an official proposal for a wetland mesocosm installation to remediate Georgica Pond waters to the Village of East Hampton Trustees. This project is currently pending approval from the Trustees and we are hopeful to begin installation in Summer 2018.

Lab Work: Bench-scale work using planar optode imaging of oxygen dynamics was investigated to examine diel patterns of oxygenation in the root zone from common wetland plants. Preliminary results reveal a surprising continuous and persistent signal of oxygenation during all times of day, even when plants are not producing oxygen through photosynthesis. Any processes that enhance temporal or spatial variability in oxygen concentrations will likely influence nitrogen transformations. Future laboratory studies will be implemented to quantify these effects in further detail.

In addition, the Center is working to develop mechanistic models of nitrogen dynamics using STELLA software. The model is currently in the developmental phase and incorporates of several submodels including hydrological models and nitrogen dynamics to predict nitrogen removal from constructed wetland systems. Data from the wetland mesocosms are being used to verify the model. Once refined, it is our hope that this model will be applied to inform components that can be manipulated to improve treatment performance.

The Nature Conservancy: The Center has worked with The Nature Conservancy to develop a full-scale constructed wetland as an I/A OWTS. The system was installed in December 2019. The system operate as a two-stage nitrogen removal system consisting of a series of planted recirculating gravel filters followed by a denitrifying woodchip box. The primary treatment objective of these wetlands is to produce an average yearly effluent TN concentration below 10 mg/L. These wetlands will also serve an experimental purpose and will be operated to test the effect of different plant species (wetland species versus ornamental plants) on total nitrogen removal. The results of this work will be used to inform future design considerations for this technology.

Wetlands Treatment System Guidance Document: CCWT has prepared a guidance document for the design and construction of a generic wetlands treatment system for publication and use by engineers and installers, which provides the details of implementing this system for General Use within Suffolk County. The document has been submitted to Suffolk County DHS for review as of the writing of this document.

7.2. Biochar

The following summary includes the set of experiments in which biochar was produced by pyrolyzing wood chips (WC) at three different temperatures, 300°C, 500°C and 700°C and for two environments, namely, N₂ (named MWC) and CO₂ (named CWC). The synthesized biochar was characterized using various techniques such as Scanning Electron Microscopy (SEM), Fourier Transform Infrared Spectroscopy (FTIR), Carbon-Nitrogen Sulfur (CNS), and Brunauer–Emmett–Teller (BET) surface area and porosity analyzer.

The raw material used was wood chips obtained from the Stony Brook university workshop. The obtained raw material was sieved using a 425 µm sieve and then dried in an oven for 2h at 100°C to remove all moisture. The dried raw material was stored in a cool and dry place until pyrolysis was conducted.

About 2.5 g of the dried wood chips (labeled as WC) were loaded into an alumina crucible and placed inside the tube furnace. The biochar was produced using a stepwise procedure, where it was gradually heated in CO₂ atmosphere (99.99%, 0.05 L min⁻¹) to target temperatures of 300, 500, and 700°C with the heating rate 10°C/minute. The biochar was then held at these target temperatures for 90 min. Then the samples were allowed to cool to room temperatures. The samples produced at 300, 500, and 700°C were labeled CWC300, CWC500, and CWC700 accordingly. A similar procedure was employed to prepare samples in N₂ atmosphere. Similar to CO₂ prepared samples, the N₂ pyrolyzed samples were labelled WC300, WC500, and WC700. After high temperature treatment, the samples were crushed using a mortar and pestle and stored for further characterization and nitrate adsorption experiments.



In order to determine the effects of pyrolysis temperature and atmosphere on NO_3^- adsorption capacity of the prepared samples, the batch adsorption experiments were carried out in 50-mL centrifuge tubes. For each run, 0.02 g biochar sample was added to 20 mL solutions of 10 mg 10 mg N-L-1 with pH of the solution being adjusted to $\text{pH}=4.0$. The samples were agitated in a shaker at room temperature for 24 h and then centrifuged at 2500 rpm for 10 minutes. The supernatant was then filtered using ashless filter paper with cutoff pore size of $2.5 \mu\text{m}$ (Whatman 42, Whatman Corp., Kent, UK). Finally, the concentration of nitrate was determined using a UV-vis spectrophotometer at the wavelength of 220 nm.

Figure 11 shows the effects of the pyrolysis atmosphere and temperature on the nitrate adsorption capacity of the biochar. When compared to untreated woodchips, all treated biochars exhibited an increased adsorption capacity. Furthermore, there were notable differences between biochars treated in CO_2 and N_2 atmosphere. For CO_2 treated woodchips, their NO_3^- adsorption capacity initially increased with the increased temperature, with the highest adsorption capacity being 87.96 mmol/kg at 300°C . This increase can be attributed to such properties of biochar as surface area and charge, which are known to be affected by pyrolysis conditions.

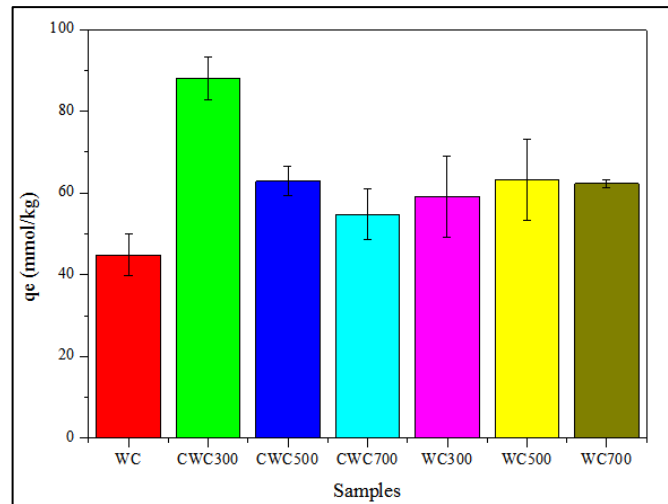

Figure 11 - Nitrogen Adsorption Capacity

7.3. MBR Using Cellulose Membrane & ANNAMOX

On-site wastewater is one of the major sources of excess nutrient (i.e., nitrogen and phosphorus) loading to ground water and ultimately coastal ecosystems. In conventional treatment systems, only a limited level of nitrogen can be removed. Membrane bioreactors (MBRs) have been used for municipal wastewater treatment, and therefore may be a viable alternative treatment for I/A OWTS.

The effluent from the bioreactor passes through a membrane unit, which serves as a physical barrier to separate particles and the effluent. The MBR effluent has higher quality, and the capital cost is comparable to conventional systems (when designed for same effluents quality). Moreover, they can be designed as automated systems, which requires less operational maintenance that makes them ideal for on-site wastewater treatment. This research seeks to develop a novel MBR for efficient nitrogen removal from on-site wastewater with lower energy and maintenance. In order to achieve this goal, our research objectives include:

- Achieve efficient nitrogen removal from on-site wastewater using a moving bed biofilm membrane reactor with optimum micro-aeration cycles;
- Characterize the system performance under a variety of operation conditions, such as F:M ratio; hydraulic retention time (HRT), solids retention time (SRT), recycle and backwash frequency;
- Evaluate the biofilm formation and identify the major foulants formed at the membrane surface at various operation conditions;
- Elucidate the microbial community composition and function at various operation conditions and different nitrogen removal efficiencies.



CCWT aims to apply the MBR developed from lab-scale condition to remove nitrogen from real on-site wastewater. On-site wastewater has unique characteristics when compared to that of municipal wastewater treatment plants. These characteristics include: low C:N ratio, fluctuating inflow rate, various levels of nutrients, and sensitivity to environmental perturbations. These are all important factors to be considered while scaling-up the MBR application to on-site wastewater treatment.

A small number of studies have considered and investigated the application of MBR for small-scale decentralized wastewater treatment, and among those only a few have focused on nitrogen removal performance and key operation parameters of these systems.

In this study, we seek to understand and apply the rationale behind nitrogen removal in the designed MBR system and find the optimum operational conditions while achieving efficient nitrogen removal. Another focus of the bioreactor study is to elucidate the microbial community composition and function at various operation conditions and different nitrogen removal efficiencies. With the information gained from this study, we can manipulate the microbial community involved in the reactor to improve nutrients removal. These figures show the schematic of the moving bed biofilm membrane bioreactor (MBBR-MBR) and nitrogen cycle in the MBBR.

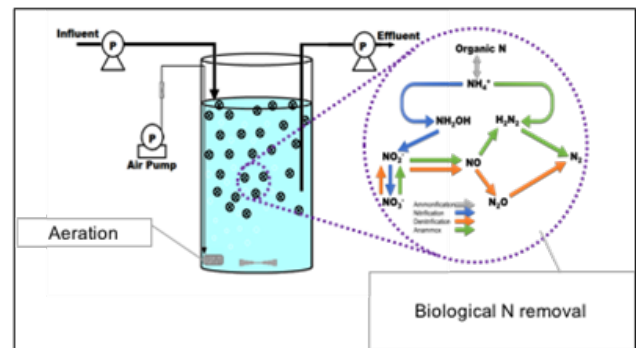
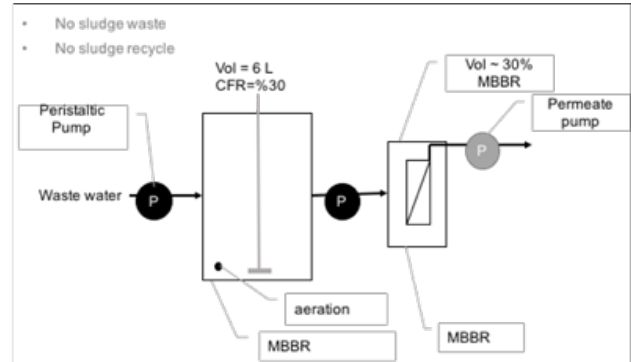
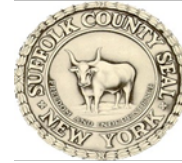

Figure 12 - MBBR-MBR

7.4. Membrane Bioreactor (MBR) Using Cellulose Membrane

In the 16-17 annual report, we showed that the novel nanocellulose-coated electrospun membrane, developed in our lab, has a decent antibiofouling properties (see Fig. 24a of the 16-17 annual report) due to the repulsion forces between the foulants (protein molecules) in wastewater and the membrane surface. These preliminary antifouling properties of the nanocellulose-coated membrane (hereinafter-called E-CNF) motivated us to engineer the coating of nanocellulose more delicately and get more enhanced antifouling properties. Also, the water flux through the E-CNF was comparable with the commercial membranes (see Fig. 25 of the 16-17 annual report). We hypothesized that if we change the thickness of the nanocellulose layer (barrier layer), we can increase the water flux through the membrane while retaining, or even enhancing, its antifouling property.



During the past six months, the Center developed a new method that enables us to control the thickness of the nanocellulose layer coated on the electrospun mat. This can be achieved by changing the concentration of the nanocellulose in the coating solution. We developed membranes with three nanocellulose barrier layer thicknesses and measured the thickness of this layer by cross-sectional SEM imaging. As illustrated in Figure 13, the thickness of the three nanocellulose-coated membranes have been determined to be around 264 nm, 210 nm, and 108 nm (hereinafter referred to as E-CNF1, E-CNF2, and E-CNF3, respectively).

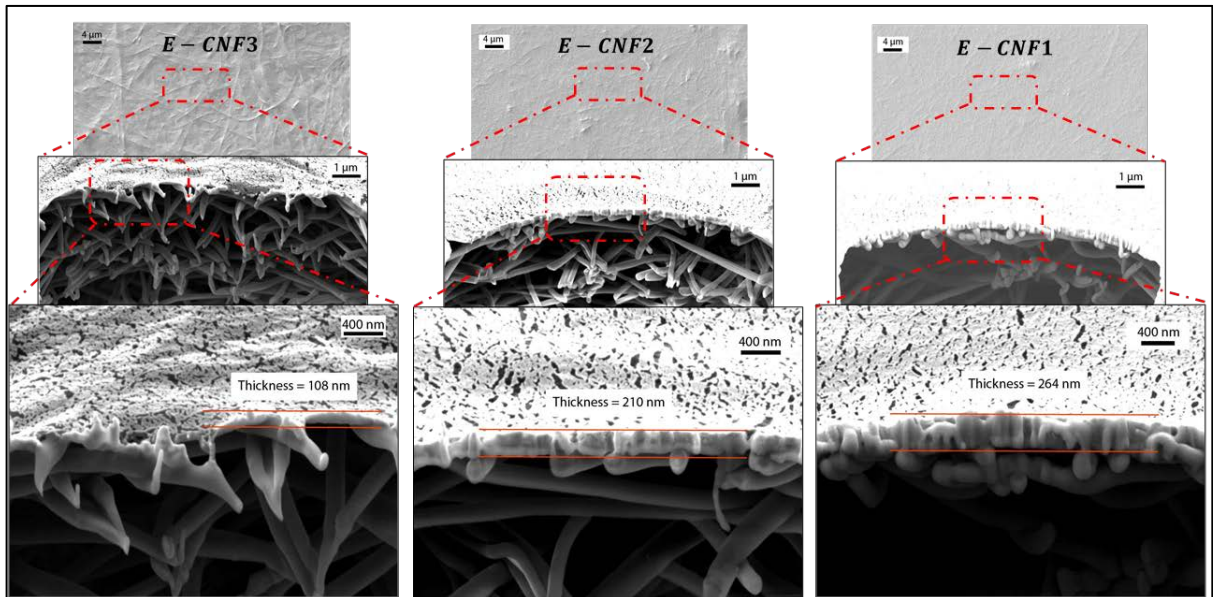

Figure 13 - Cross-Sectional SEM Images of the E-CNF1, E-CNF1, and E-CNF3 at Different Magnifications

The surface of the nanocellulose is abundant in functional groups with high affinity to water molecules that make them especially suitable as superhydrophilic coating layers to lure water molecules to the surface of the membranes. Therefore, contact angle (CA) test is paramount in determining the behavior of the membrane surface and the membrane flux in contact with an aqueous medium. Fig. 29 depicts the dynamic water contact angles of the E-CNF1, E-CNF3 and several conventional commercial membranes in the course of time. The contact angles for PVDF-A6, PVDF-V6, PES-LX and PAN-PX (all commercial membranes) are 72.5°, 63.3°, 87.6°, and 57.1°, respectively, upon contact with the surface. The contact angles of these membranes at different time frames exhibit a very slight change over the course of time, as shown in Figure 13. The dynamic contact angles of the E-CNF1 and E-CNF3, on the other hand, are very different from these membranes.

During these past months, the Center developed a new method that enables us to control the thickness of the nanocellulose layer coated on the electrospun mat. This can be achieved by changing the concentration of the nanocellulose in the coating solution. We developed membranes with three nanocellulose barrier layer thicknesses and measured the thickness of this layer by cross-sectional SEM imaging. The thickness of the



three nanocellulose-coated membranes have been determined to be around 264 nm, 210 nm, and 108 nm (hereinafter referred to as E-CNF1, E-CNF2, and E-CNF3, respectively).

To take E-CNF1 as an example, it shows a contact angle of 20.3° upon contact with the surface that is much lower than all the conventional polymeric membranes. However, the most interesting phenomenon is the “change in the contact angle by time”, where only after 1 s and 4 s, the contact angle decreases to 14.8° and 9.4°, respectively, and the water droplet is totally absorbed into the membrane matrix after 20 s (or less).

This demonstrates that immediately after the droplet touches the E-CNF surface, it is attracted onto the functional group-rich nanocellulose surface, which facilitates its pathway through the nanochannels created by the cellulose nanofibers and is ultimately sucked into the spacious vacant pores in the electrospun mat. This phenomenon accounts for the very rapid decreasing trend in the contact angles of the E-CNF that may lead to a very high water flux.

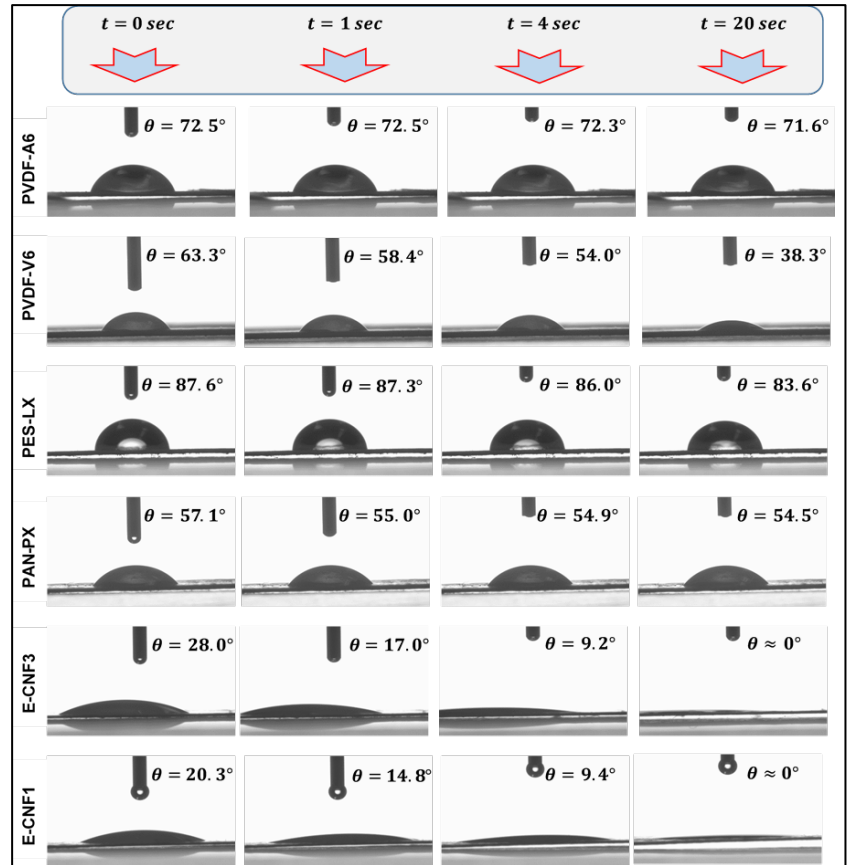

Figure 14 - Dynamic Contact Angle Measurements

Furthermore, zeta potential test was carried out to examine the negative charge on the membrane surface. This test is crucial in determining the (anti)fouling properties of the membranes, since the lower zeta potential values (more negative values) are expected to yield more antifouling membranes.

Figure 14 shows that E-CNFs, irrespective of the thickness of the nanocellulose layer coated on it, has a more negatively-charged surface compared with the conventional commercial membranes, most probably due to the abundant number of carboxylate functional groups, whereas conventional membranes only contain a limited number of polar groups. The E-CNF membranes all have a zeta potential of ~-45 mV at the pH of 6.5 (pH value of the wastewater), while the zeta potentials of the commercial membranes range from -20 ~ -30 mV at the same pH value. Therefore, E-CNF has a more negative surface charge density compared with the conventional membranes and thus is expected to have better antifouling property.

CCWT will be conducting the pure water flux test and fouling test using our custom-made filtration system. We hypothesize, based on the results from the intricate scientific characterization of the membranes presented above, that the nanocellulose-coated membranes show high water flux and low fouling properties. CCWT will provide updates on:

- Pure water flux test of the nanocellulose-coated membranes with different thicknesses and their comparisons with the commercial membranes,



- Biofouling properties of the nanocellulose-coated membranes with different thicknesses and their comparisons with the commercial membranes.

7.5. Pharmaceuticals and Personal Care Products (PPCPs)

Sample Collection: During this time, samples were collected from the MASSTC NRB systems NY1, NY2, and NY3 in September 2017, December 2017, and March 2018, respectively, and from the constructed wetland system at Sylvester Manor in September 2017 and October 2017, and from the Riverhead Waste Water Treatment Plant in November 2017. All samples were collected and processed. Samples were then stored at -18°C prior to analysis by LC-TOF-MS.

Sample Analysis: During this period, samples from the Sylvester Manor constructed wetland taken in September 2017 were analyzed. Data from this analysis are presented in these tables. In this system, fewer of the 36 compounds screened for were detected in any sample compared to the MASSTC influent, which is reasonable given the less diverse set of influent sources. Nearly all compounds detected were significantly removed.

Finally, samples from the MASSTC NRB systems X, Y, and Z (samples previously collected in November 2016) were also analyzed. Table 29 presents these data. Of importance, nearly all compounds analyzed were significantly removed. Our current hypotheses for these reductions include 1) degradation and 2) adsorption. Looking to the future, we will evaluate these two contemporaneous processes by column experiments at the newly constructed research facility.

7.6. Potentially Toxic Metals (PTMs)

Analyses were performed to detect the presence of potentially toxic metals (PTMs). These metals may not only be harmful to human health but also have the potential to affect the efficiency of alternative wastewater treatment systems from performing nitrification and denitrification. Samples were analyzed for PTMs using an inductively coupled plasma mass spectrometer (ICP-MS), as well as an omega plate reader spectrophotometer.

Table 29 - Sylvester Manor Percent Removals of OWCs

OWC	Removal (%)
Acetaminophen	95
DEET	88
Caffeine	94
Paraxanthine (human metabolite of caffeine)	96
Nicotine	66
Cotinine (human metabolite of nicotine)	55
Ciprofloxacin	92

Table 29 - MASSTC NRBs Percent Removals of OWCs

OWC	X	Y	Z
Caffeine	99.998	99.998	99.998
Cimetidine	95	97	16
Ranitidine	99.97	99.98	99.9
Cotinine	99.7	97	99
Acetaminophen	99.998	99.998	99.998
Trimethoprim	99.99	99.73	99.99
Atenolol	95	99	-35
Lamotrigine	100	73	97
Venlafaxine	98	96	92
Metoprolol	99.9997	99.61	99.9997
Propranolol	98	99.7	99.9
Sulfamethoxazole	99.9	99.7	99.9
Diphenhydramine	99.8	97	95
Diltiazem	99.9	99.9	99.8
Fluoxetine	99.7	99.8	99.6
Carbamazepine	88	75	99
TCEP	66	47	86
DEET	91	99.8	88



Table 30 shows data for samples collected on 11/15/17 from the three pilot systems at the MASSTC, referred to as New York systems 1, 2 and 3. Most PTMs were found in concentrations well below the Suffolk county limit for metals in wastewater. For example, the 'acceptable' concentration limit set by Suffolk County for Cr, Cu, Zn, Cd and Pb in sludge is 100, 400, 5000, 10, and 50 ppb, respectively. In contrast, the maximum concentration identified in NRB "NY1" influent (i.e., being dosed to the system) were significantly lower than this, with values of 3, 34, 9.2, 0.2, and 0.3 ppb for these elements, respectively. However, final effluent values were 1.7, 0.6, 2.9, 0.1, and 0.5 ppb, indicating removals for most PTMs close to 100%.

This pattern was furthermore repeated in each NRB NY2 and NY3, despite variable configurations and materials used, underscoring the removal efficiency for PTMs of NRBs in general. Additionally, several of the PTMs showed a decrease over time (See Table 31 below), suggesting a possible depletion from the original building materials. The Center will continue to monitor these and other metals in NRBs and other I/A OWTS.

Looking to the future, two bench scale experiments have been proposed to further our understanding of the effect of PTMs. In the variable conditions of an NRB (and other I/A systems such as constructed wetlands, permeable reactive barriers, etc.), large internal cycling of compounds between reduced and oxidized forms likely occurs (i.e., oxidation and reduction of many PTMs and potentially toxic organic compounds due to the presence/absence of oxygen). These redox oscillations are likely to control the speciation of certain PTMs and, therefore, may impact the availability and toxicity of these metals in and released from a NRB. We aim to observe the effect that oxic and anoxic conditions have on the release of PTMs from a bench scale column representative of a real world NRB. One-meter long columns made of clear PVC pipes equipped with an oxygen optode will be set up vertically in front of an oxygen optode camera. Oxygen concentrations will be monitored, and images captured by planar optode imaging. Oxygen images can be used to calculate geochemical parameters and determine the concentration of oxygen in the vertical profile of the system. The oxygen camera will capture photos every five mins for a two-week period. Samples will be collected daily from the influent, effluent, and three ports.

Table 30 - ICP-MS Data MASSTC (New York Systems)

	Cr	Cu	Zn	Cd	Pb
Average Influent	3	33.77	9.16	0.21	0.34
New York 1					
Septic Tank	2.42	20.45	12.58	0.28	0.34
Lysimeter 1	0.5	25.55	11.25	0.86	b.d.*
Lysimeter 2	0.67	24.97	13.48	0.37	0.13
Effluent	1.76	0.63	2.89	0.14	0.46
New York 2					
Septic Tank	2.47	19.41	10.73	0.04	0.3
Lysimeter 1	1.2	16.77	2.92	0.07	0.04
Effluent	1.75	2.48	1.22	0.04	0.09
New York 3					
Septic Tank	3.78	21.59	11.96	0.06	0.29
Lysimeter 1	1.63	14.46	22.17	0.5	0.05
Lysimeter 2	4.91	0.5	4.28	0.06	0.21
Effluent	3.02	15.15	5.36	0.07	0.06
Suffolk County Limits	100	400	5,000	10	50

*b.d. = below detection

Table 31 - ICP-MS Data MASSTC (New York Systems) - 03/20/18 (ppb)

	Cr	Cu	Zn	Cd	Pb
Average Influent	9.67	33.76	28.82	b.d.	14
New York 1					
Septic Tank	14.05	31.45	18.24	0.66	16.34
Lysimeter 1	13.12	26.32	16.97	1.2	16.06
Lysimeter 2	13.14	27.46	17.95	1.24	15.53
Effluent	13.28	9.17	23.28	0.75	16.77
New York 2					
Septic Tank	14.38	26.14	19.69	0.25	15.46
Lysimeter 1	13.08	19.8	7.28	0.52	16.43
Effluent	31.61	15.65	10.35	1.71	131.1
New York 3					
Septic Tank	19.54	31.31	23.29	2.61	18.15
Lysimeter 1	19.1	26.38	13.62	3.09	17.88
Lysimeter 2	18.53	13.75	26.65	2.62	19.42
Effluent	17.19	20.58	11.91	2.49	17.47
Suffolk County Limits	100	400	5,000	10	50



The materials will consist of C-33 state sand containing an already established microbial community. Woodchips will be taken from the NY2 bed due to the established microbial community. The second proposed future bench scale experiment is linked to the first one and will allow us to observe the effect that high levels of PTMs have on rates of nitrification and denitrification. Laboratory incubations will be conducted to investigate the effect of PTMs on nitrogen transformations.



8. EVALUATION OF O & M REQUIREMENTS OF EXISTING I/A OWTS

This section provides an overview of the anticipated operations and maintenance cost for I/A OWTS.

8.1. NRB 1.0 O & M Requirements

The CCWT NRB systems require minimal maintenance. The septic tank effluent filters should be cleaned every 6 months based on normal use. The pumps that feed the sand filter do not require maintenance except for the occasional hosing off of grease that may have accumulated on the pumps and float. CCWT will be monitoring the condition of the installed systems over time to develop a protocol for maintenance activities. Electrical costs associated with the system are less than \$100 per year.

8.2. O&M Requirements for Provisionally Approved Systems

Article 19 of the Suffolk County Sanitary Code requires all I/A OWTS be maintained in accordance with manufacturer recommendations, at a minimum of every 12 months. All the Provisionally Approved systems currently include 3-year O&M agreements and are maintained every six (6) months. Maintenance can include the following activities depending on the technology:

- Measure scum and sludge and recommend pumping as needed
- Check floats, controls, and alarms
- Check recirculation rates
- Clean all submerged pumps
- Change filter in aerators and blowers
- Measure air flow through system
- Check pump system and flush out Pressurized Shallow Drainfields

8.3. O&M Costs for Provisionally Approved Systems

Technology	One Year Contract Cost
Hydro-Action AN	\$250.00
Orenco Advantex AX20-RT	\$271.66
Norweco Hydro-Kinetic	\$300.00
Norweco Singlair TNT	\$315.00



8.4. Repair and Replacement Costs for Provisionally Approved Systems

Technology	Item	Cost	Life Expectancy
Norweco Singulair TNT	Aerator Replacement	\$500.00	10 years
	Control Panel Replacement	\$1,200.00	20 years
Hydro-Action AN Series	Blower Replacement	\$400.00	10 years
	Blower Rebuild	\$100.00	
	Recirculation Pump Replacement	\$400.00	10 years
	Float Replacement	\$80.00	5-10 years
	Control Panel Replacement	\$1,200.00	20 years
Orenco Advantex AX20-RT	Recirculation Pump Replacement	\$800.00	10 years
	Float Replacement	\$80.00	5-10 years
	Control Panel Replacement	\$1,500.00	20 years
Norweco Hydro-Kinetic	Blower Replacement	\$300.00	10 years
	Blower Rebuild	\$100.00	
	Recirculation Pump Replacement	\$500.00	10 years
	Control Panel Replacement	\$1,200.00	20 years

8.5. Estimated Electrical Costs for Provisionally Approved Technologies

Technology	1-year Electrical Consumption (kWh/year)	Increased Electrical Costs per Year (\$0.22/ kWh)
Orenco Advantex AX20-RT	335.80 kWh	\$73.88
Hydro-Action AN	734.26 kWh	\$161.54
Norweco Singulair TNT	979.66 kWh	\$215.53
Norweco Hydro-Kinetic	1051.20 kWh	\$231.26

Note: The Hydro-Action unit utilizes a mixer pump during start-up. The pump use is discontinued after startup, and usage data will vary after the start-up period.



9. CONCLUSIONS AND RECOMMENDATIONS

The NRBs installed by CCWT proves that all variations of the NRB process produces an effluent concentration of less than 10 mg/L of total nitrogen. However, further research is needed on year-round residences in Suffolk County. Further research of NRB's is required in order to bring the installation costs to affordable levels. CCWT has been working with the SCDHS to develop a cost efficient and passive I/A OWTS.

New emerging technologies such as the Nitrogen Reducing Biofilters being evaluated and piloted by SBU's CCWT are promising alternatives to current propriety technologies being evaluated. SCDHS and CCWT should work cooperatively to aggressively pursue, evaluate, and install these technologies in Suffolk County.

The I/A OWTS Demonstration Program was an effective method to spark the use of innovative and alternative technologies in Suffolk County. The demonstration program allowed the assessment of system design, operation & maintenance, installation issues, and the overall ability of each technology to meet nitrogen reduction objectives in Suffolk County. Though all technologies participating in the demonstration program have certification for nitrogen reductions (through NSF245 or EPA's ETV testing), not all technologies proved capable of reducing total nitrogen to at or below 19 mg/L in Suffolk County.

The performance standard of 19 mg/L represents the most stringent requirement for TN that does not allow for increase in density. The County should not consider changing the performance standard of 19 mg/L until there is sufficient data justifying a 90% confidence in the results as concluded by Horsely Witten Group in the analysis of Barnstable County's septic system database. (i.e. there should be a minimum of 12 samples of 20 systems of a technology before the County considers changing the performance standard)

Although Provisionally Approved systems were able to perform to the standard of 19 mg/L during demonstration testing, 3 out of 4 technologies are not currently meeting 19 mg/L during provisional bi-monthly sampling. It is recommended that SCDHS meet with manufacturers in 2018 and address performance issues, it is still early in the Provisional Sampling and there is time to correct performance. SCDHS should request and require implementation of corrective action plans from Norweco and Orenco to improve their performance, and SCDHS should continue monitoring the performance of all provisionally approved systems to ensure compliance with standards are maintained.



No text this page



Appendix A
CCWT Research Facility Schematic Layout of Experiments

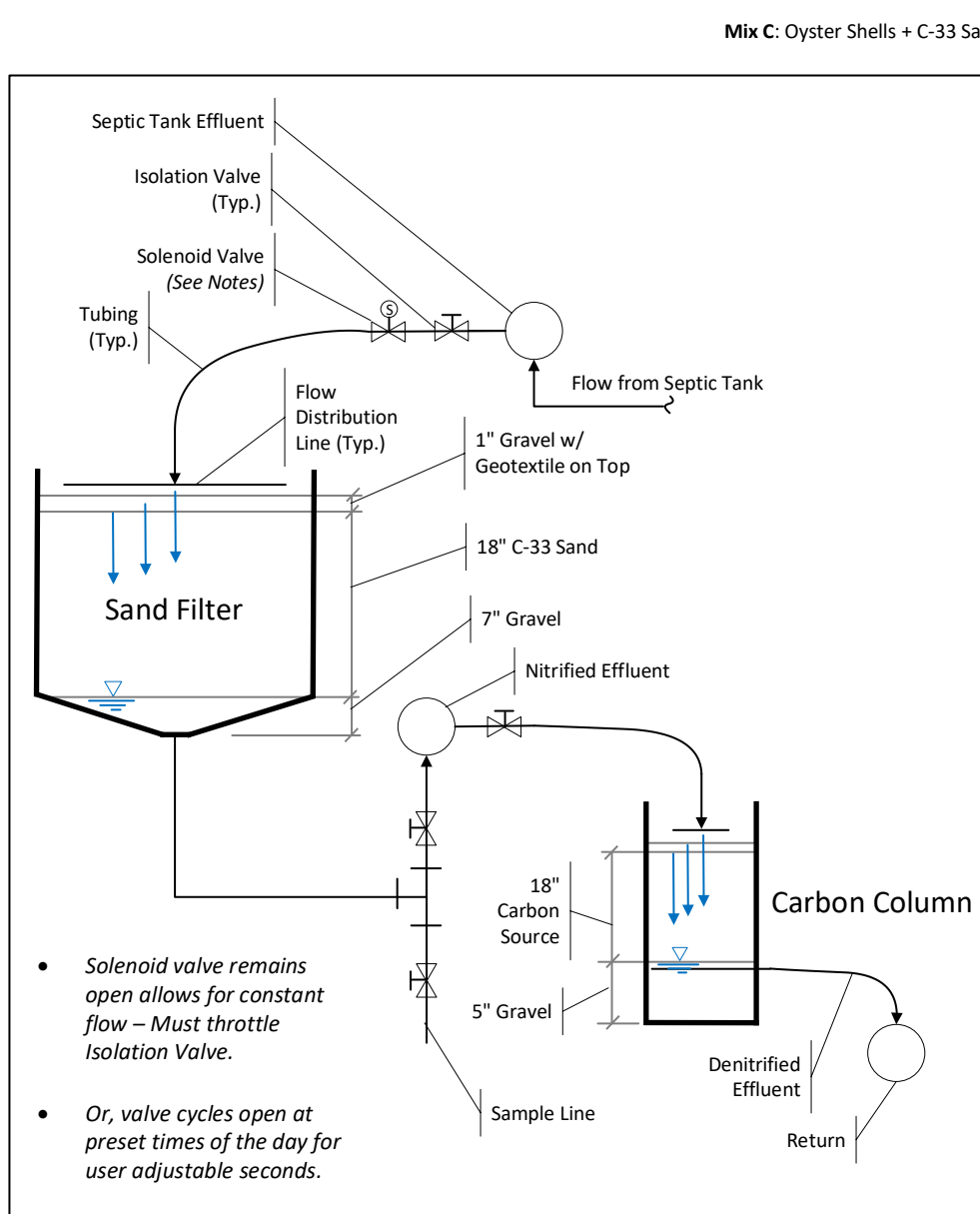

Elevational Schematic

- Solenoid valve remains open allows for constant flow – Must throttle Isolation Valve.
- Or, valve cycles open at preset times of the day for user adjustable seconds.

- No Woodchips – No Silt (Typ.)
- No Woodchips - Sand + Silt (Typ.)
- Non-Processed Woodchips – No Silt (Typ.)
- Processed Woodchips w/ Silt (Typ.)
- Processed Woodchips – No Silt (Typ.)
- Non-Processed Woodchips w/ Silt (Typ.)
- Processed Woodchips – No Silt (Typ.)
- No Woodchips - No Silt (Typ.)

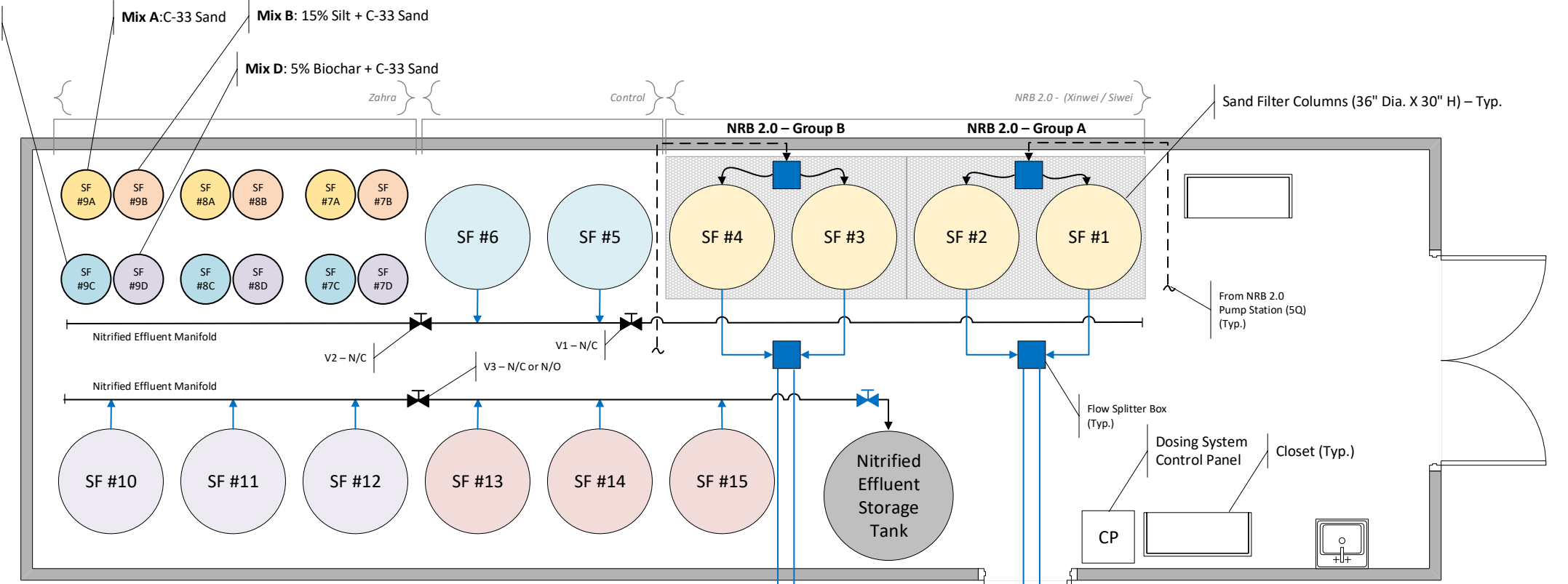

Top Shelf Plan

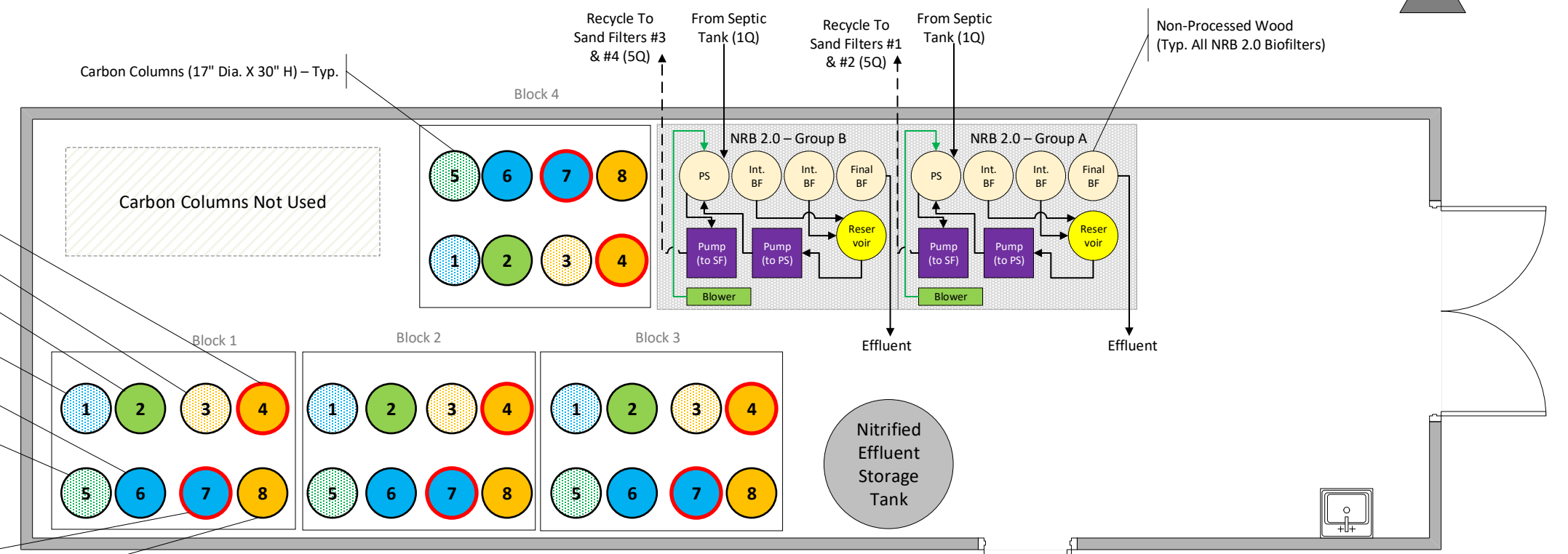

Bottom Shelf Plan

Note: Saturated Columns Shown in Red Line

CCWT Research Facility Schematic Layout of Experiments

Suffolk County Department of Health Services

360 Yaphank Avenue
Yaphank, NY, 11980

New York State Center for Clean Water Technology at Stony Brook University

Advanced Energy Research and Technology Center (AERTC)
1000 Innovation Road, Room 100
Stony Brook, NY 11794-6044